

KGT Series

KGT



MOTION-K
모션케이



경기도 안산시 단원구 산단로 19번길 180.
101동 2층 4호

T E L : 070-8292-5130

F A X : 031-935-0997

Mobile : 010-4723-5130

E-mail : motion-k@motion-k.com

대표 김 남 형

Indication of Model Numbers

KGT	-	60	-	B	-	10	-	MOTOR
Type KGT		Model 60 85 110 135 200		Output Table Supporting Bearing B : Ball Bearing C : Cross Roller Bearing ----- H : Ball Bearing (60#) / Cross Roller Bearing (85# ~ 250#)		Ratio 1-Stage 5, 10, 18 2-Stage 25, 50, 100 ----- 1-Stage 10, 18 2-Stage 50, 100		Motor Type Motor Brand & Model No.

저소음

헬리컬기어 사용으로 부드럽고 조용한 운전가능

Quiet operation

Grinding spiral bevel gear & Helical gears contribute to reduce vibration and noise.

고강성, 높은 토크

uncage needle bearing 사용, 강성과 토크를 높임

High Rigidity & High Torque

High rigidity & high torque are achieved by crossed roller bearings.

고효율

효율 95%이상

High Efficiency

Efficiency exceeds 95%.

Features of KGT Series

KGT Series 제품 특성

다양한 모터 체결 용이

Servo 및 Stepping Motor 그밖의 각종 Motor와 장착이 용이하며 감속기 입력축과 Motor Shaft를 연결하는 Collet Locking 방식으로 역학상 확실한 체결력과 높은 속도에서도 백래쉬가 발생하지 않고 동력을 효율적으로 전달합니다.

Flexible Motor Connection

The modular design of motor connection plate is suitable for any brand servomotor and stepmotor. The input-end and the motor are coupled through a collet locking mechanism. It has passed dynamical balance analysis to assure concentricity and balance on the connection and no backlash for power transmission while running at high speed.

외부 표면 및 베어링

- 몸체는 알루미늄 합금 소재로써 산화 및 부식 방지에 강한 내환경 표면처리
- 하중 정도의 상황에 따라 Ball Bearing 및 Cross Roller Bearing 선택 가능

중공테이블 구조

복잡한 배선 작업 및 배관 작업이 용이

Hollow Structure Design

Make it convenient for electric wiring or piping work.

Helical Gear

기어 맞물림이 평기어의 2배 이상인 Helical Gear 적용으로 동작 소음을 최소화하고 고출력, 저소음, 저백래쉬를 실현했습니다.

Helical Gear Design

The speed reduction mechanism employs helical gears, which provides two times meshing rate of teeth when comparing with regular spur gears. In addition, it also Specification extremely smooth running, low noise, high torque output and low backlash.

고정도 위치결정

한방향 반복 오차 정밀도 ± 10 sec
백래쉬 : 1단 ≤ 1 arcmin , 2단 ≤ 2 arcmin
로스트모션 : 1단 2 arcmin , 2단 3 arcmin

High Accuracy

Repetitive Positioning Accuracy ± 10 sec
Torsional BackLash : 1-stage ≤ 1 arcmin
2-stage ≤ 2 arcmin
Lost Motion : 1-stage 2 arcmin
2-stage 3 arcmin



간편한 장착

장비의 테이블이나 Arm을 직접 설치하여 부품수를 줄이고 유지보수가 편리합니다.

Direct Mounting of Workpiece

The rotating table allows for direct mounting of workpiece for added convenience in workpiece loading.



고정밀, 고강도 기어

정밀 가공된 알루미늄 Housing을 적용했으며 HRC57~60의 경도와 정밀도 향상을 위해 열처리 후 스카이빙 연마공정을 적용하여 DIN6 Class(JIS 2급) 이내의 등급을 유지합니다.

High Precision Gear Machining

The housing of reducer is made by aluminum alloy, and precision machining by CNC machine. Precision teeth grinding assures gear accuracy reaches DIN6 class and carburized to hardness 58-60HRC.

* 측면과 하단방향 취부는 축방향 하중이 감소 되어질 수 있으므로 Crossed Roller Bearing Type을 권장합니다.

* 50W이하 모터 사용시 감속기선정 관련하여 본사와 문의바랍니다.

MODEL : KGT-60B

RATIO : 5, 10, 18 (1-Stage)



Unit: mm

Model Code	60B-1
A1	46, 63, 60
A2	M3, M4, M5
A3	30, 40, 50
A4	46, 55

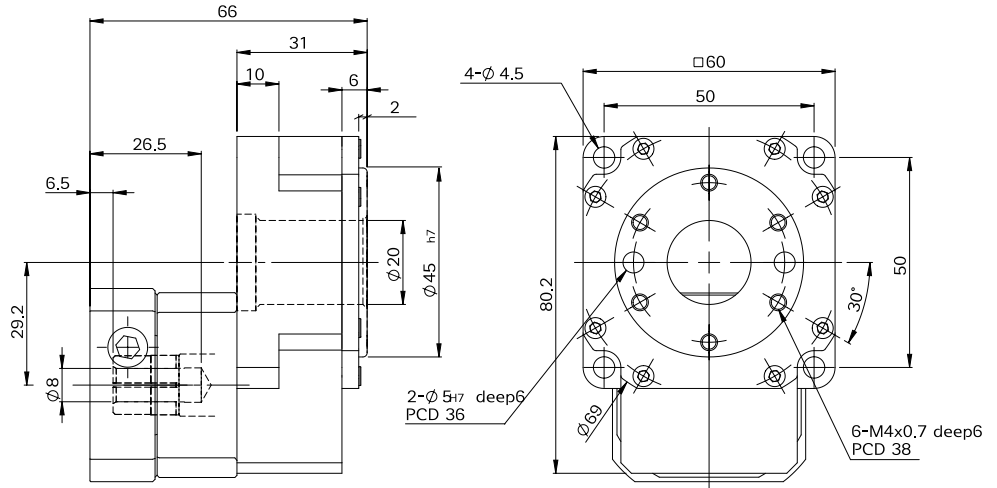
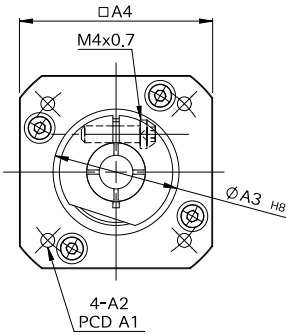
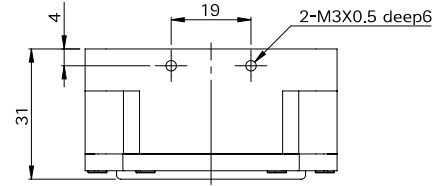

Characteristic		Unit	Ratio	KGT-60B-1
Output Table Supporting Bearing			5~18	Ball Bearing
Rated Output Torque	T _{2N}	Nm	5	5
			10	4
			18	3
Max. Output Torque Emergency Stop Torque	T _{2NOT}	Nm	5~18	2 Time of Rated Output Torque
Inertia Moment		kg.m ²	5~18	777 x 10 ⁻⁷
Output Permissible Speed	n ₂	rpm	5~18	300
Torsional Backlash		arcmin	5~18	≤ 1
Lost Motion		arcmin	5~18	2 (0.033°)
Repetitive Positioning Accuracy		arcsec	5~18	± 10 (0.0028°)
Permissible Thrust Load	F _{2aB}	N	5~18	350
Permissible Moment Load		Nm	5~18	7
Runout of Output Table Surface		mm	5~18	0.01
Runout of Output Table Inner / Outer Diameter		mm	5~18	0.01
Parallelism of Output Table		mm	5~18	0.02
Protection Class			5~18	IP 65
Weight ± 3%		kg	5~18	0.54

MODEL : KGT-60B

RATIO : 25, 50, 100 (2-Stage)



KGT

Unit: mm

Model Code	60B-2
A1	46, 63, 60
A2	M3, M4, M5
A3	30, 40, 50
A4	46, 55

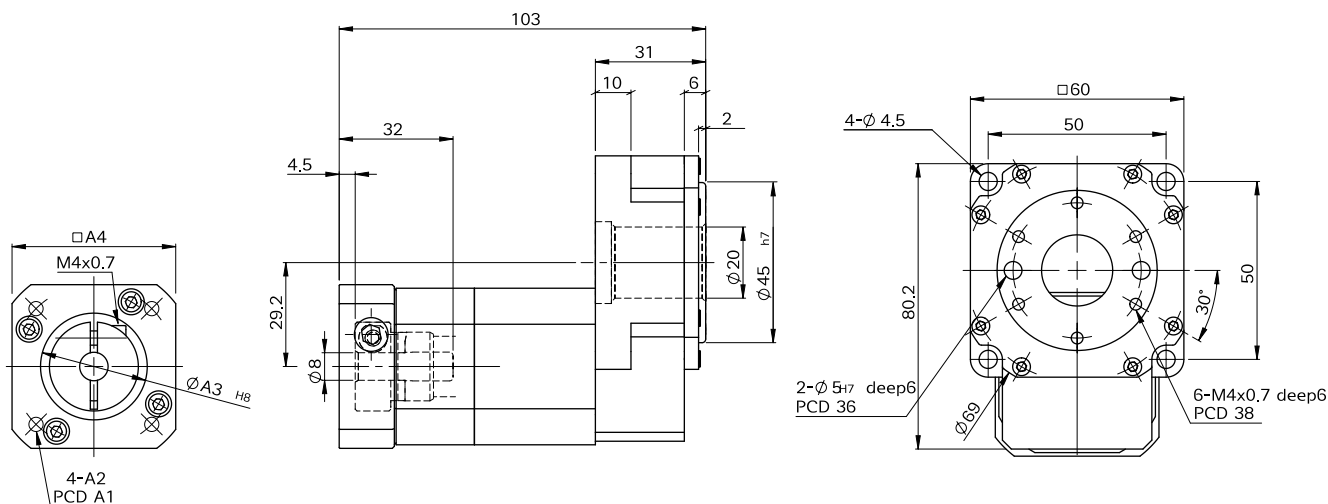
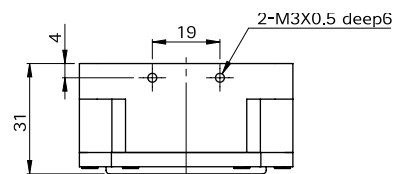

Characteristic		Unit	Ratio	KGT-60B-2
Output Table Supporting Bearing			25~100	Ball Bearing
Rated Output Torque	T_{2N}	Nm	25	5
			50	4
			100	4
Max. Output Torque Emergency Stop Torque	T_{2NOT}	Nm	25~100	2 Time of Rated Output Torque
Inertia Moment		kg.m ²	25~100	777×10^{-7}
Output Permissible Speed	n_2	rpm	25~100	300
Torsional Backlash		arcmin	25~100	≤ 2
Lost Motion		arcmin	25~100	3 (0.05°)
Repetitive Positioning Accuracy		arcsec	25~100	± 15 (0.0042°)
Permissible Thrust Load	F_{2aB}	N	25~100	350
Permissible Moment Load		Nm	25~100	7
Runout of Output Table Surface		mm	25~100	0.01
Runout of Output Table Inner / Outer Diameter		mm	25~100	0.01
Parallelism of Output Table		mm	25~100	0.02
Protection Class			25~100	IP 65
Weight ± 3%		kg	25~100	1.1

MODEL : KGT-85B

RATIO : 5, 10, 18 (1-Stage)



Unit: mm

Model Code	85B-1
A1	46, 63, 70
A2	M3, M4, M5
A3	30, 40, 50
A4	46, 55, 60
A5	8 ~ 14
A6	85.5 (86.5)

* ()는 감속비 1/18인 경우

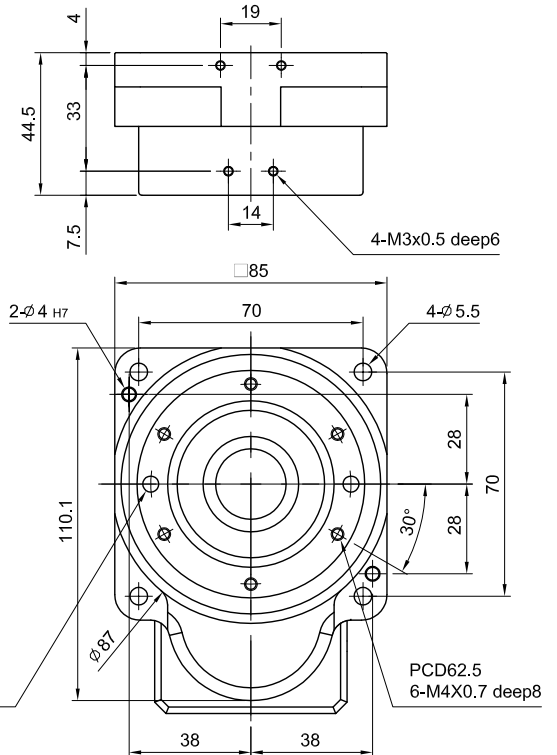
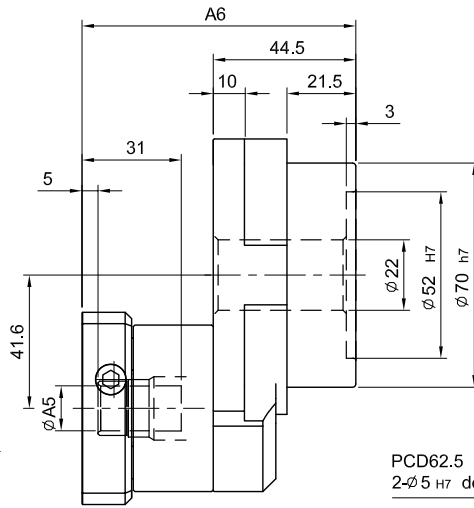
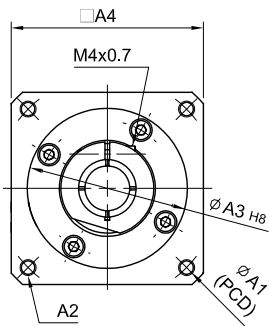

Characteristic		Unit	Ratio	KGT-85B-1
Output Table Supporting Bearing			5~18	Ball Bearing
Rated Output Torque	T _{2N}	Nm	5	18
			10	14
			18	10
Max. Output Torque Emergency Stop Torque	T _{2NOT}	Nm	5~18	2 Time of Rated Output Torque
Inertia Moment		kg.m ²	5~18	1,268 x 10 ⁻⁶
Output Permissible Speed	n ₂	rpm	5~18	300
Torsional Backlash		arcmin	5~18	≤ 1
Lost Motion		arcmin	5~18	2 (0.033°)
Repetitive Positioning Accuracy		arcsec	5~18	± 10 (0.0028°)
Permissible Thrust Load	F _{2aB}	N	5~18	600
Permissible Moment Load		Nm	5~18	12
Runout of Output Table Surface		mm	5~18	0.01
Runout of Output Table Inner / Outer Diameter		mm	5~18	0.01
Parallelism of Output Table		mm	5~18	0.02
Protection Class			5~18	IP 65
Weight ± 3%		kg	5~18	1.17

MODEL : KGT-85B

RATIO : 25, 50, 100 (2-Stage)



KGT

Unit: mm

Model Code	85B-2
A1	46, 63, 70
A2	M3, M4, M5
A3	30, 40, 50
A4	46, 55, 60
A5	8 ~ 14

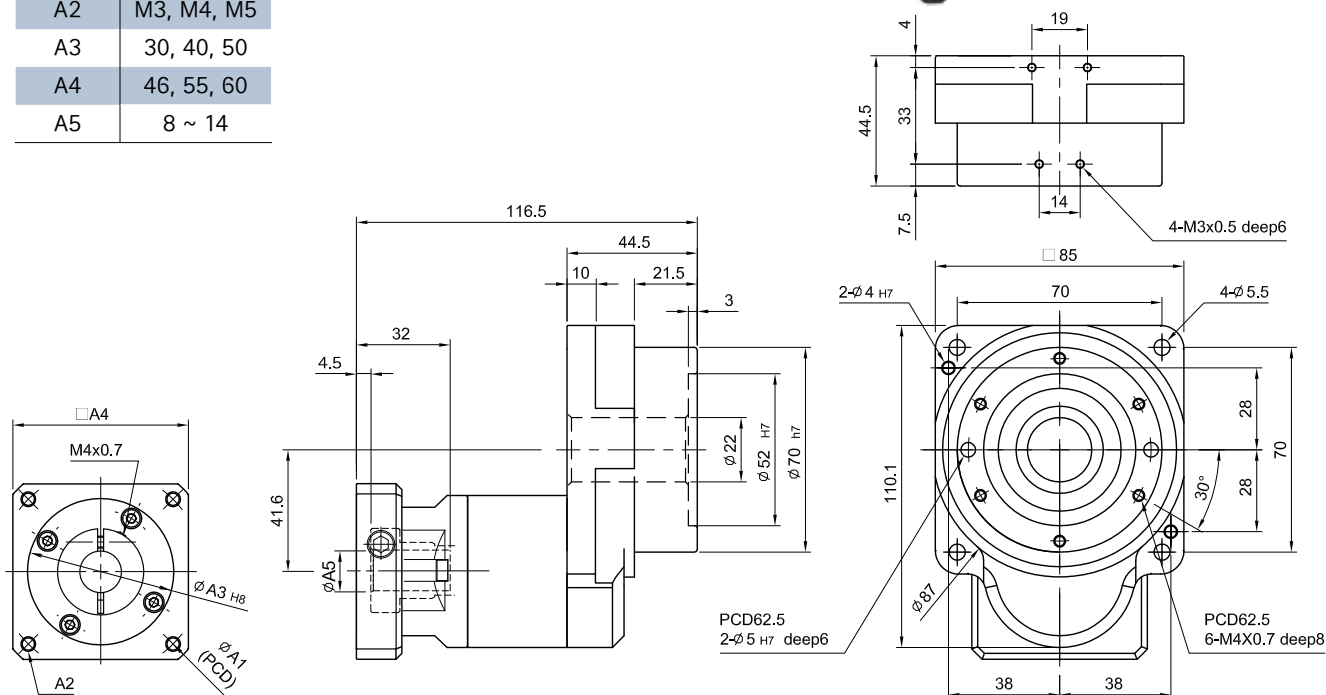

Characteristic		Unit	Ratio	KGT-85B-2
Output Table Supporting Bearing			25~100	Ball Bearing
Rated Output Torque	T_{2N}	Nm	25	18
			50	14
			100	14
Max. Output Torque Emergency Stop Torque	T_{2NOT}	Nm	25~100	2 Time of Rated Output Torque
Inertia Moment		kg.m ²	25~100	1,268 × 10 ⁻⁶
Output Permissible Speed	n_2	rpm	25~100	300
Torsional Backlash		arcmin	25~100	≤ 2
Lost Motion		arcmin	25~100	3 (0.05°)
Repetitive Positioning Accuracy		arcsec	25~100	± 15 (0.0042°)
Permissible Thrust Load	F_{2aB}	N	25~100	600
Permissible Moment Load		Nm	25~100	12
Runout of Output Table Surface		mm	25~100	0.01
Runout of Output Table Inner / Outer Diameter		mm	25~100	0.01
Parallelism of Output Table		mm	25~100	0.02
Protection Class			25~100	IP 65
Weight ± 3%		kg	25~100	1.95

MODEL : KGT-110B

RATIO : 5, 10, 18 (1-Stage)

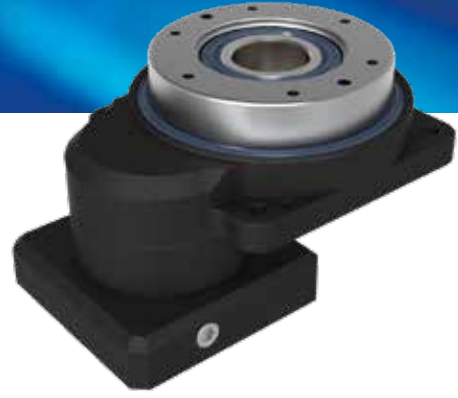

Unit: mm

Model Code	110B-1
A1	70, 75, 90
A2	M4, M5, M6
A3	50, 60, 70
A4	64, 70, 80
A5	88.5 (90.5)

* ()는 감속비 1/18인 경우

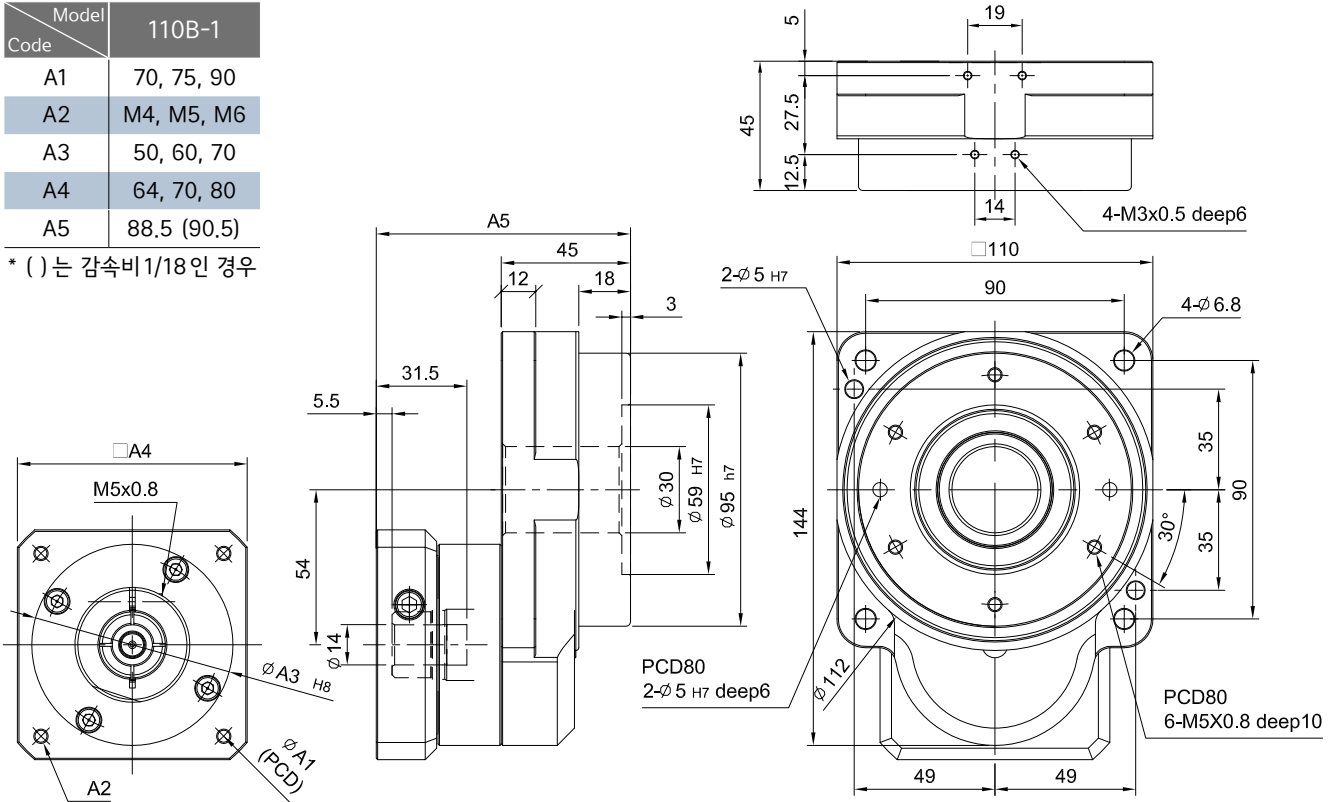

Characteristic		Unit	Ratio	KGT-110B-1
Output Table Supporting Bearing			5~18	Ball Bearing
Rated Output Torque	T _{2N}	Nm	5	33
			10	26
			18	19
Max. Output Torque Emergency Stop Torque	T _{2NOT}	Nm	5~18	2 Time of Rated Output Torque
Inertia Moment		kg.m ²	5~18	1,562 x 10 ⁻⁶
Output Permissible Speed	n ₂	rpm	5~18	300
Torsional Backlash		arcmin	5~18	≤ 1
Lost Motion		arcmin	5~18	2 (0.033°)
Repetitive Positioning Accuracy		arcsec	5~18	± 10 (0.0028°)
Permissible Thrust Load	F _{2aB}	N	5~18	800
Permissible Moment Load		Nm	5~18	16
Runout of Output Table Surface		mm	5~18	0.015
Runout of Output Table Inner / Outer Diameter		mm	5~18	0.015
Parallelism of Output Table		mm	5~18	0.025
Protection Class			5~18	IP 65
Weight ± 3%		kg	5~18	2.54

MODEL : KGT-110B

RATIO : 25, 50, 100 (2-Stage)



KGT

Unit: mm

Model Code	110B-2
A1	70, 75, 90
A2	M4, M5, M6
A3	50, 60, 70
A4	64, 70, 80

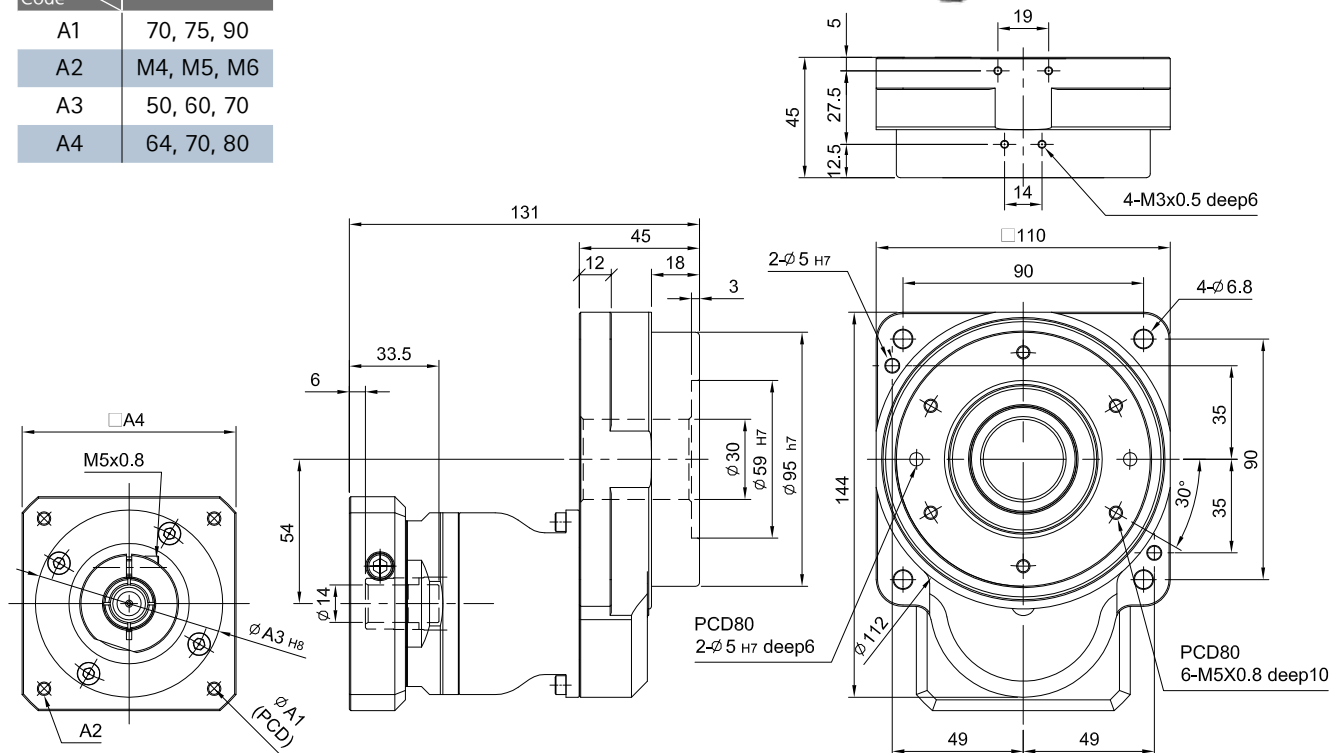

Characteristic		Unit	Ratio	KGT-110B-2
Output Table Supporting Bearing			25~100	Ball Bearing
Rated Output Torque	T_{2N}	Nm	25	33
			50	26
			100	26
Max. Output Torque Emergency Stop Torque	T_{2NOT}	Nm	25~100	2 Time of Rated Output Torque
Inertia Moment		kg.m ²	25~100	1,562 x 10 ⁻⁶
Output Permissible Speed	n_2	rpm	25~100	300
Torsional Backlash		arcmin	25~100	≤ 2
Lost Motion		arcmin	25~100	3 (0.05°)
Repetitive Positioning Accuracy		arcsec	25~100	± 15 (0.0042°)
Permissible Thrust Load	F_{2aB}	N	25~100	800
Permissible Moment Load		Nm	25~100	16
Runout of Output Table Surface		mm	25~100	0.015
Runout of Output Table Inner / Outer Diameter		mm	25~100	0.015
Parallelism of Output Table		mm	25~100	0.025
Protection Class			25~100	IP 65
Weight ± 3%		kg	25~100	3.76

MODEL : KGT-135B

RATIO : 5, 10, 18 (1-Stage)



Unit: mm

Model Code	135B-1
A1	70, 75, 90
A2	M4, M5, M6
A3	50, 60, 70
A4	64, 70, 80
A5	14 ~ 19
A6	108 (111)

* ()는 감속비 1/18인 경우

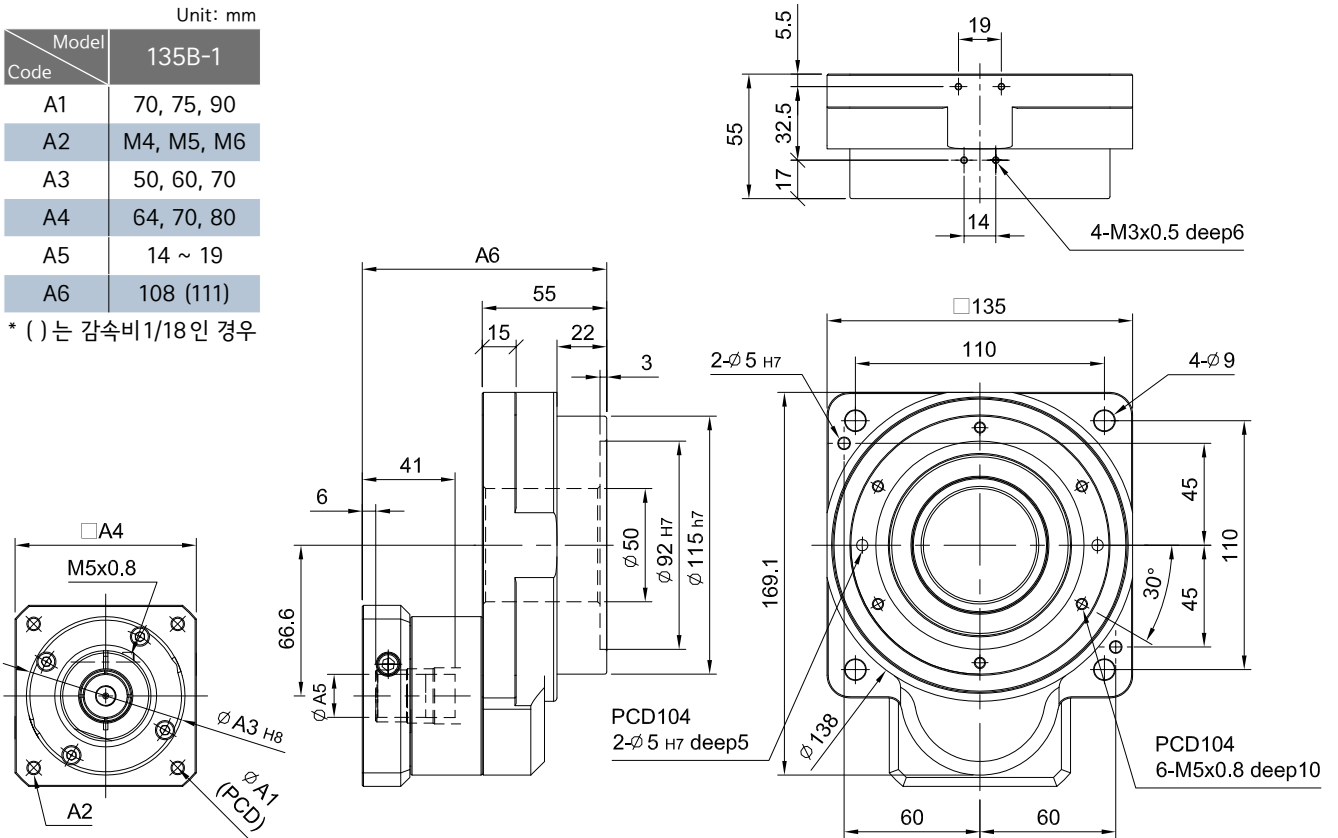

Characteristic	Unit	Ratio	KGT-135B-1	
Output Table Supporting Bearing		5~18	Ball Bearing	
Rated Output Torque	T _{2N}	Nm	5	43
			10	34
			18	25
Max. Output Torque Emergency Stop Torque	T _{2NOT}	Nm	5~18	2 Time of Rated Output Torque
Inertia Moment	kg.m ²	5~18	2,918 x 10 ⁻⁶	
Output Permissible Speed	n ₂	rpm	5~18	300
Torsional Backlash		arcmin	5~18	≤ 1
Lost Motion		arcmin	5~18	2 (0.033°)
Repetitive Positioning Accuracy		arcsec	5~18	± 10 (0.0028°)
Permissible Thrust Load	F _{2aB}	N	5~18	1,450
Permissible Moment Load		Nm	5~18	30
Runout of Output Table Surface		mm	5~18	0.015
Runout of Output Table Inner / Outer Diameter		mm	5~18	0.015
Parallelism of Output Table		mm	5~18	0.025
Protection Class			5~18	IP 65
Weight ± 3%		kg	5~18	3.83

MODEL : KGT-135B

RATIO : 25, 50, 100 (2-Stage)



KGT

Unit: mm

Model Code	135B-2
A1	70, 75, 90
A2	M4, M5, M6
A3	50, 60, 70
A4	64, 70, 80
A5	14 ~ 19
A6	33.5, 41.5
A7	6
A8	141, 149

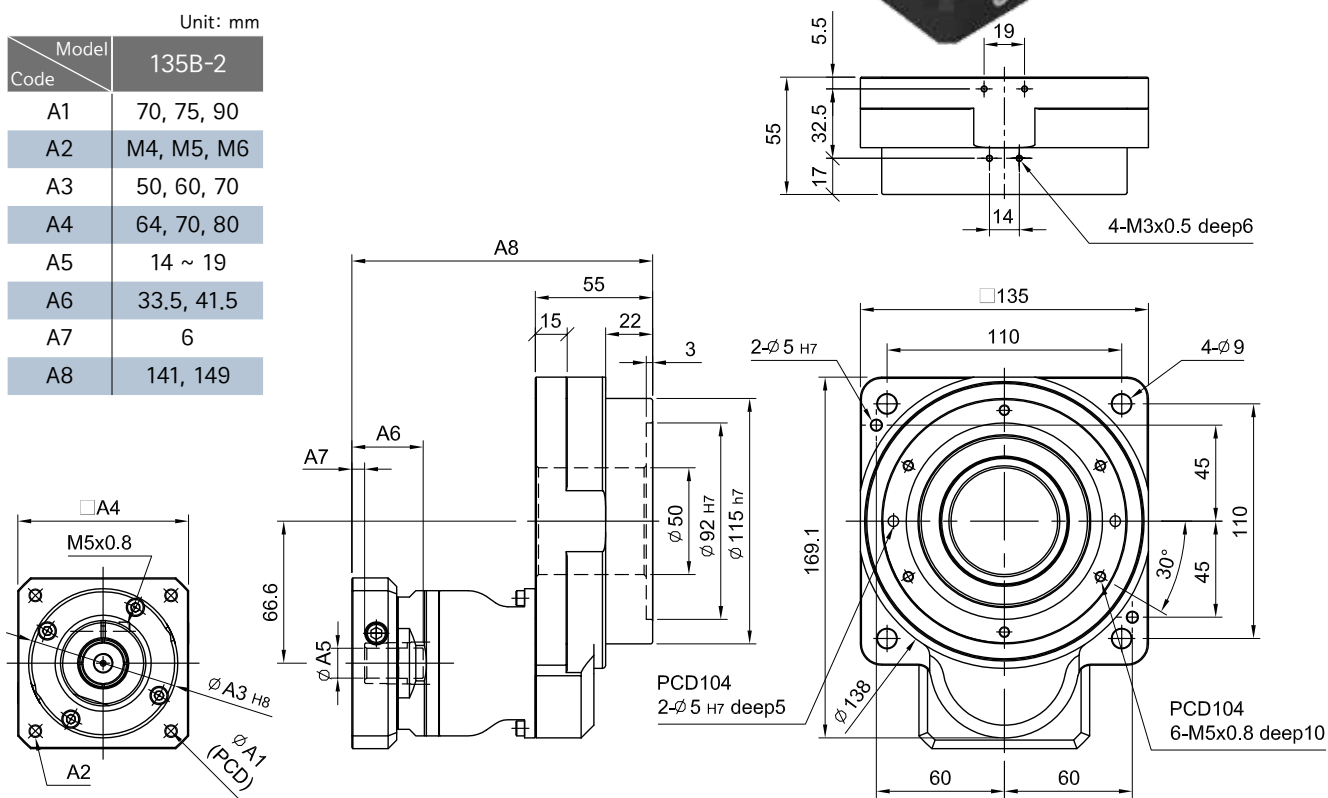

Characteristic		Unit	Ratio	KGT-135B-2
Output Table Supporting Bearing			25~100	Ball Bearing
Rated Output Torque	T_{2N}	Nm	25	43
			50	34
			100	34
Max. Output Torque Emergency Stop Torque	T_{2NOT}	Nm	25~100	2 Time of Rated Output Torque
Inertia Moment		kg.m ²	25~100	$2,918 \times 10^{-6}$
Output Permissible Speed	n_2	rpm	25~100	300
Torsional Backlash		arcmin	25~100	≤ 2
Lost Motion		arcmin	25~100	3 (0.05°)
Repetitive Positioning Accuracy		arcsec	25~100	± 15 (0.0042°)
Permissible Thrust Load	F_{2aB}	N	25~100	1,450
Permissible Moment Load		Nm	25~100	30
Runout of Output Table Surface		mm	25~100	0.015
Runout of Output Table Inner / Outer Diameter		mm	25~100	0.015
Parallelism of Output Table		mm	25~100	0.025
Protection Class			25~100	IP 65
Weight ± 3%		kg	25~100	4.92

MODEL : KGT-200B

RATIO : 5, 10, 18 (1-Stage)



Unit: mm

Model Code	200B-1
A1	90, 100, 115, 145
A2	M5, M6, M8
A3	70, 80, 95, 110
A4	92, 110, 130
A5	19 ~ 24
A6	44.5, 57.5
A7	8.5, 7.5
A8	125.5, 138.5 (139.5)

* () 는 감속비 1/18 인 경우

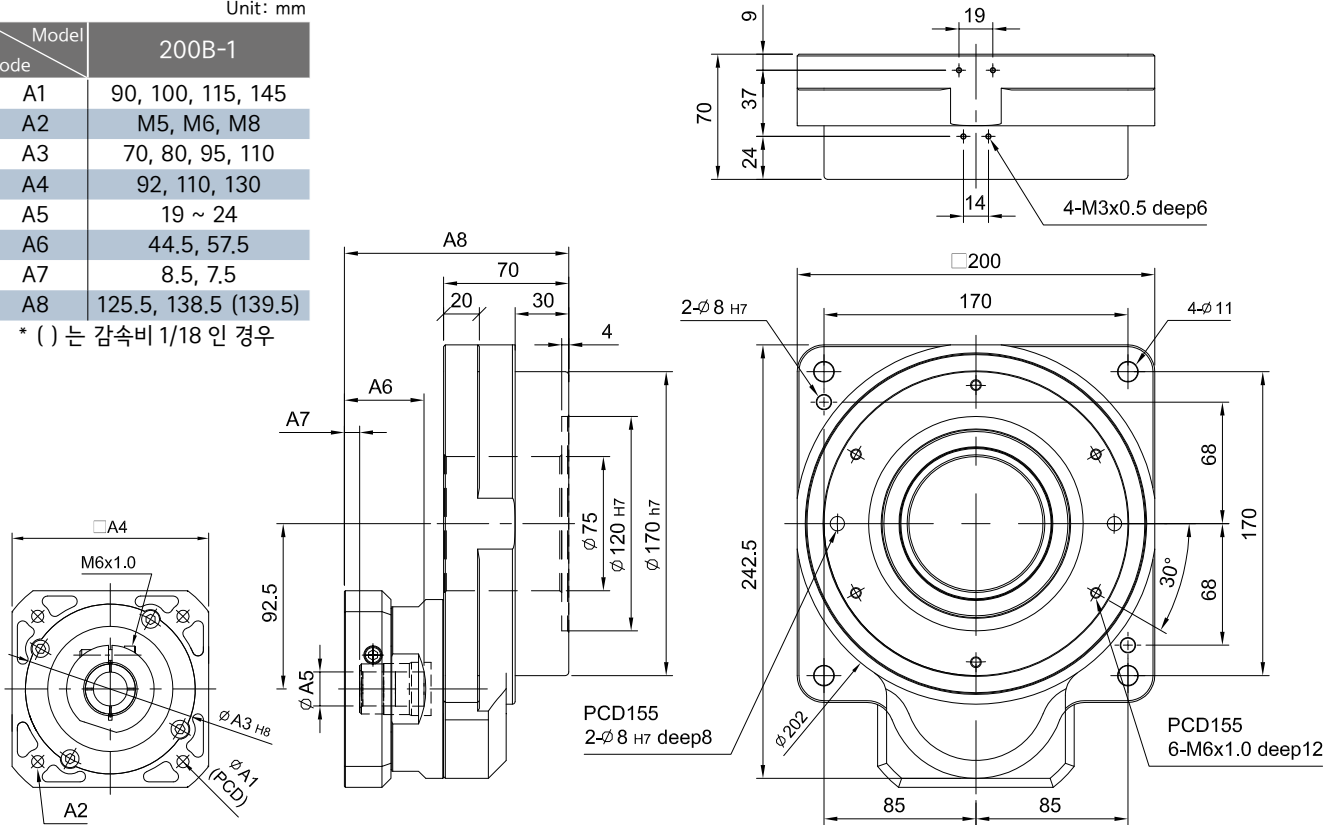

Characteristic	Unit	Ratio	KGT-200B-1	
Output Table Supporting Bearing		5~18	Ball Bearing	
Rated Output Torque	T _{2N}	Nm	5	142
			10	112
			18	85
Max. Output Torque Emergency Stop Torque	T _{2NOT}	Nm	5~18	2 Time of Rated Output Torque
Inertia Moment		kg.m ²	5~18	29,072 x 10 ⁻⁶
Output Permissible Speed	n ₂	rpm	5~18	300
Torsional Backlash		arcmin	5~18	≤ 1
Lost Motion		arcmin	5~18	2 (0.033°)
Repetitive Positioning Accuracy		arcsec	5~18	± 10 (0.0028°)
Permissible Thrust Load	F _{2aB}	N	5~18	2,500
Permissible Moment Load		Nm	5~18	50
Runout of Output Table Surface		mm	5~18	0.02
Runout of Output Table Inner / Outer Diameter		mm	5~18	0.02
Parallelism of Output Table		mm	5~18	0.03
Protection Class			5~18	IP 65
Weight ± 3%		kg	5~18	10.09

MODEL : KGT-200B

RATIO : 25, 50, 100 (2-Stage)



KGT

Unit: mm

Model Code	200B-2
A1	90, 100, 115, 145
A2	M5, M6, M8
A3	70, 80, 95, 110
A4	92, 110, 130

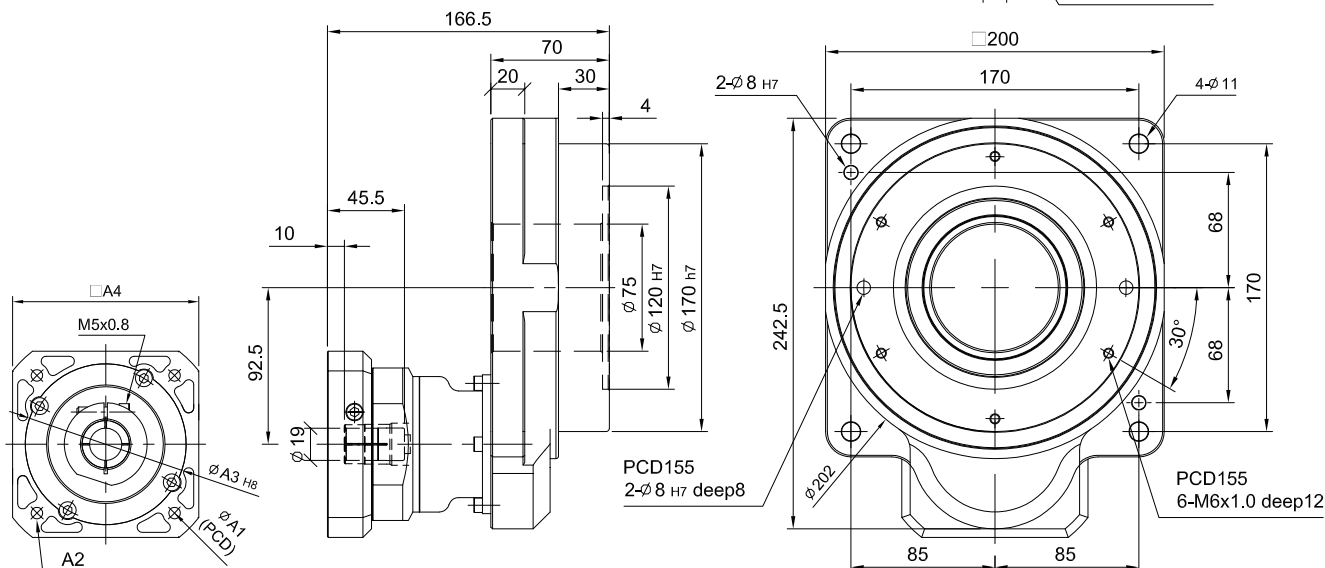
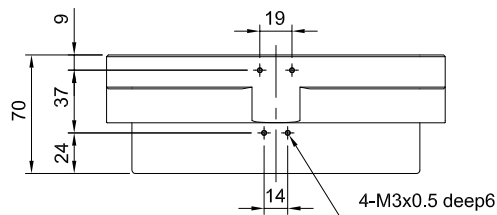

Characteristic		Unit	Ratio	KGT-200B-2
Output Table Supporting Bearing			25~100	Ball Bearing
Rated Output Torque	T_{2N}	Nm	25	142
			50	112
			100	112
Max. Output Torque Emergency Stop Torque	T_{2NOT}	Nm	25~100	2 Time of Rated Output Torque
Inertia Moment		kg.m ²	25~100	$29,072 \times 10^{-6}$
Output Permissible Speed	n_2	rpm	25~100	300
Torsional Backlash		arcmin	25~100	≤ 2
Lost Motion		arcmin	25~100	3 (0.05°)
Repetitive Positioning Accuracy		arcsec	25~100	± 15 (0.0042°)
Permissible Thrust Load	F_{2aB}	N	25~100	2,500
Permissible Moment Load		Nm	25~100	50
Runout of Output Table Surface		mm	25~100	0.02
Runout of Output Table Inner / Outer Diameter		mm	25~100	0.02
Parallelism of Output Table		mm	25~100	0.03
Protection Class			25~100	IP 65
Weight ± 3%		kg	25~100	11.8

MODEL : KGT-60C

RATIO : 5, 10, 18 (1-Stage)



Unit: mm

Model Code	60C-1
A1	46, 63, 60
A2	M3, M4, M5
A3	30, 40, 50
A4	46, 55

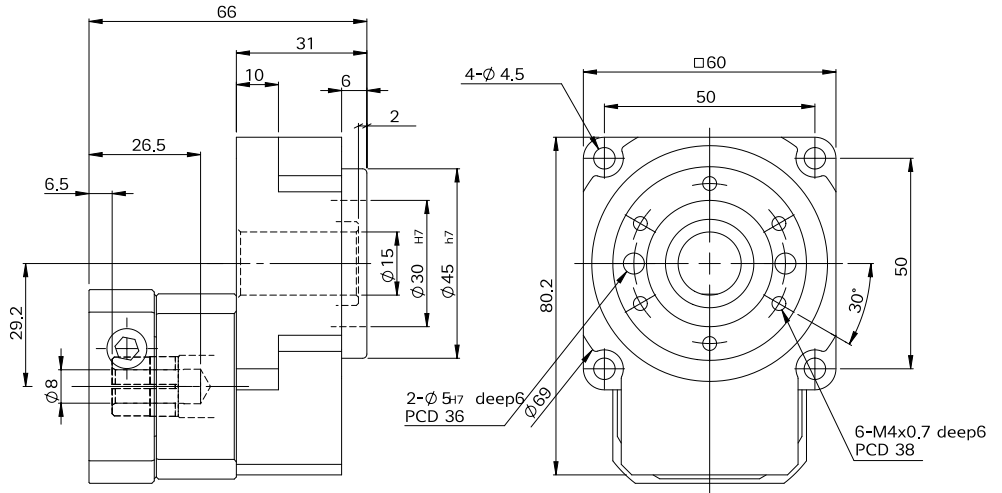
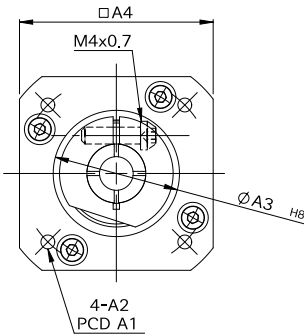
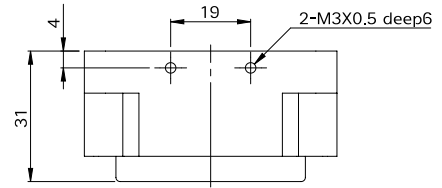

Characteristic		Unit	Ratio	KGT-60C-1
Output Table Supporting Bearing			5~18	Cross Roller Bearing
Rated Output Torque	T_{2N}	Nm	5	5
			10	4
			18	3
Max. Output Torque Emergency Stop Torque	T_{2NOT}	Nm	5~18	2 Time of Rated Output Torque
Inertia Moment		kg.m ²	5~18	735×10^{-7}
Output Permissible Speed	n_2	rpm	5~18	200
Torsional Backlash		arcmin	5~18	≤ 1
Lost Motion		arcmin	5~18	2 (0.033°)
Repetitive Positioning Accuracy		arcsec	5~18	± 10 (0.0028°)
Permissible Thrust Load	F_{2aB}	N	5~18	500
Permissible Moment Load		Nm	5~18	10
Runout of Output Table Surface		mm	5~18	0.01
Runout of Output Table Inner / Outer Diameter		mm	5~18	0.01
Parallelism of Output Table		mm	5~18	0.02
Protection Class			5~18	IP 65
Weight ± 3%		kg	5~18	0.62

MODEL : KGT-60C

RATIO : 25, 50, 100 (2-Stage)



KGT

Unit: mm

Model Code	60C-2
A1	46, 63, 60
A2	M3, M4, M5
A3	30, 40, 50
A4	46, 55

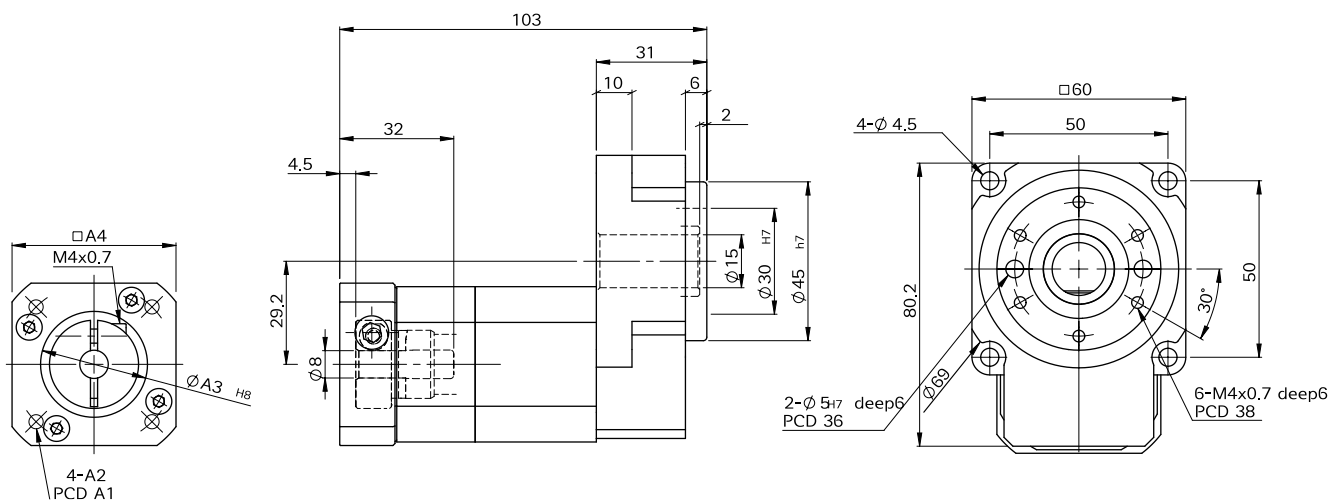
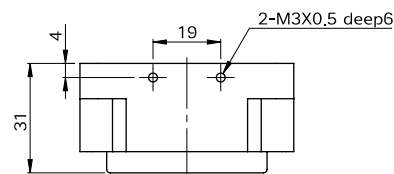

Characteristic		Unit	Ratio	KGT-60C-2
Output Table Supporting Bearing			25~100	Cross Roller Bearing
Rated Output Torque	T_{2N}	Nm	25	5
			50	4
			100	4
Max. Output Torque Emergency Stop Torque	T_{2NOT}	Nm	25~100	2 Time of Rated Output Torque
Inertia Moment		kg.m ²	25~100	735×10^{-7}
Output Permissible Speed	n_2	rpm	25~100	200
Torsional Backlash		arcmin	25~100	≤ 2
Lost Motion		arcmin	25~100	3 (0.05°)
Repetitive Positioning Accuracy		arcsec	25~100	± 15 (0.0042°)
Permissible Thrust Load	F_{2aB}	N	25~100	500
Permissible Moment Load		Nm	25~100	10
Runout of Output Table Surface		mm	25~100	0.01
Runout of Output Table Inner / Outer Diameter		mm	25~100	0.01
Parallelism of Output Table		mm	25~100	0.02
Protection Class			25~100	IP 65
Weight $\pm 3\%$		kg	25~100	1.1

MODEL : KGT-85C

RATIO : 5, 10, 18 (1-Stage)



Unit: mm

Model Code	85C-1
A1	46, 63, 70
A2	M3, M4, M5
A3	30, 40, 50
A4	46, 55, 60
A5	8 ~ 14
A6	77.5 (78.5)

* ()는 감속비 1/18인 경우

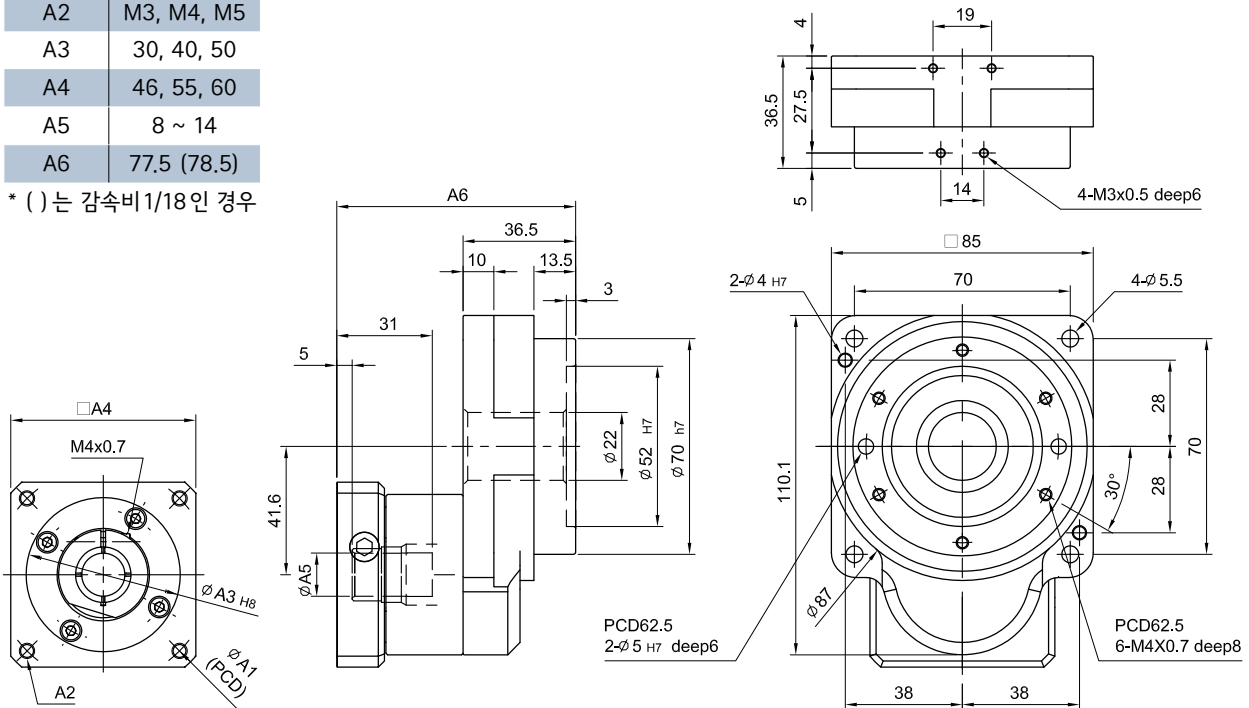

Characteristic		Unit	Ratio	KGT-85C-1
Output Table Supporting Bearing			5~18	Cross Roller Bearing
Rated Output Torque	T _{2N}	Nm	5	18
			10	14
			18	10
Max. Output Torque Emergency Stop Torque	T _{2NOT}	Nm	5~18	2 Time of Rated Output Torque
Inertia Moment		kg.m ²	5~18	1,203 x 10 ⁻⁶
Output Permissible Speed	n ₂	rpm	5~18	200
Torsional Backlash		arcmin	5~18	≤ 1
Lost Motion		arcmin	5~18	2 (0.033°)
Repetitive Positioning Accuracy		arcsec	5~18	± 10 (0.0028°)
Permissible Thrust Load	F _{2aB}	N	5~18	900
Permissible Moment Load		Nm	5~18	18
Runout of Output Table Surface		mm	5~18	0.01
Runout of Output Table Inner / Outer Diameter		mm	5~18	0.01
Parallelism of Output Table		mm	5~18	0.02
Protection Class			5~18	IP 65
Weight ± 3%		kg	5~18	1.1

MODEL : KGT-85C

RATIO : 25, 50, 100 (2-Stage)



KGT

Unit: mm

Model Code	85C-2
A1	46, 63, 70
A2	M3, M4, M5
A3	30, 40, 50
A4	46, 55, 60
A5	8 ~ 14

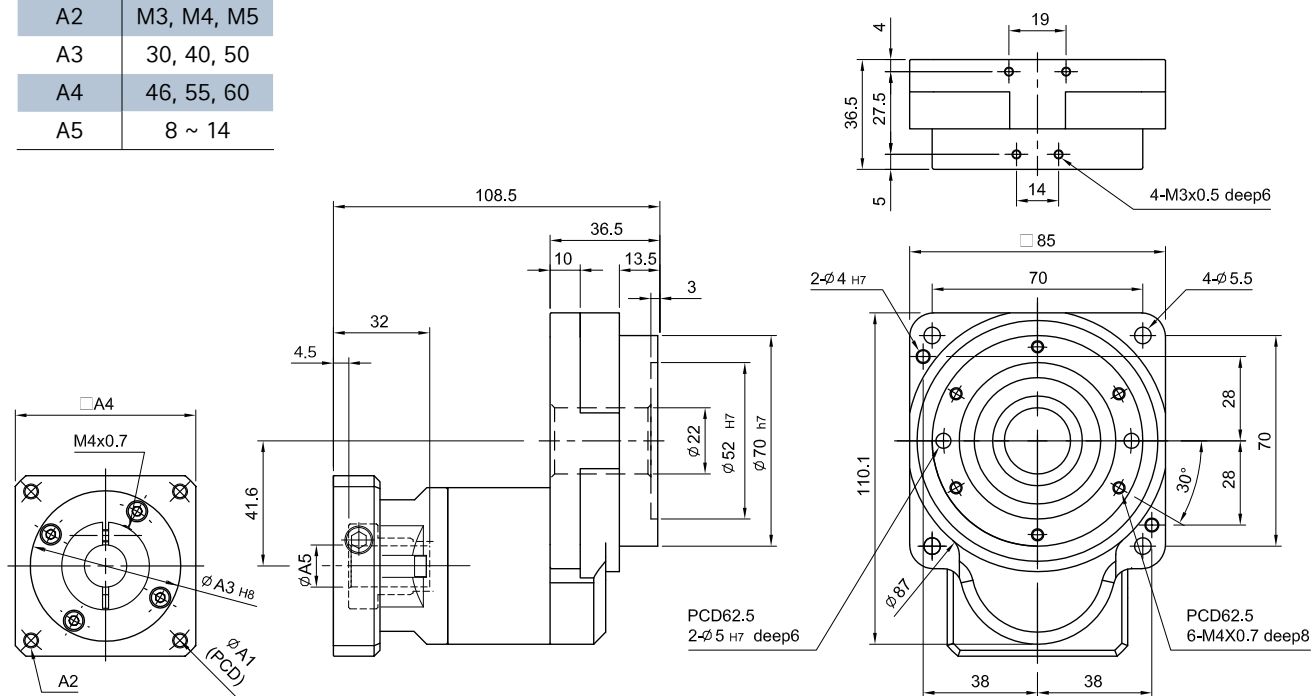

Characteristic		Unit	Ratio	KGT-85C-2
Output Table Supporting Bearing			25~100	Cross Roller Bearing
Rated Output Torque	T_{2N}	Nm	25	18
			50	14
			100	14
Max. Output Torque Emergency Stop Torque	T_{2NOT}	Nm	25~100	2 Time of Rated Output Torque
Inertia Moment		kg.m ²	25~100	$1,203 \times 10^{-6}$
Output Permissible Speed	n_2	rpm	25~100	200
Torsional Backlash		arcmin	25~100	≤ 2
Lost Motion		arcmin	25~100	3 (0.05°)
Repetitive Positioning Accuracy		arcsec	25~100	± 15 (0.0042°)
Permissible Thrust Load	F_{2aB}	N	25~100	900
Permissible Moment Load		Nm	25~100	18
Runout of Output Table Surface		mm	25~100	0.01
Runout of Output Table Inner / Outer Diameter		mm	25~100	0.01
Parallelism of Output Table		mm	25~100	0.02
Protection Class			25~100	IP 65
Weight ± 3%		kg	25~100	1.78

MODEL : KGT-110C

RATIO : 5, 10, 18 (1-Stage)

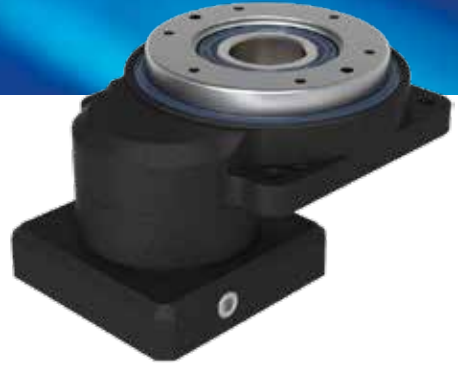

Unit: mm

Model Code	110C-1
A1	70, 75, 90
A2	M4, M5, M6
A3	50, 60, 70
A4	64, 70, 80
A5	80.5 (82.5)

* ()는 감속비 1/18인 경우

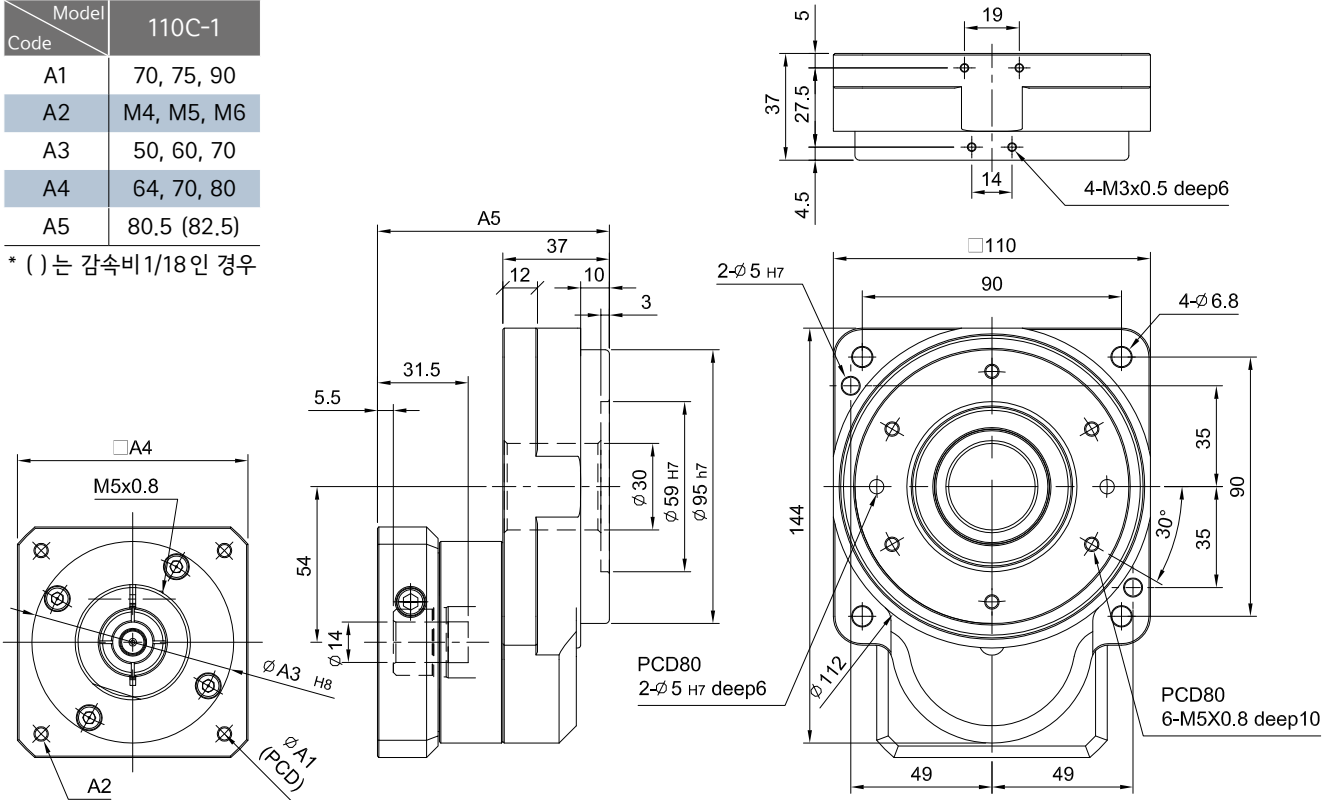

Characteristic		Unit	Ratio	KGT-110C-1
Output Table Supporting Bearing			5~18	Cross Roller Bearing
Rated Output Torque	T_{2N}	Nm	5	33
			10	26
			18	19
Max. Output Torque Emergency Stop Torque	T_{2NOT}	Nm	5~18	2 Time of Rated Output Torque
Inertia Moment		kg.m ²	5~18	1,483 x 10 ⁻⁶
Output Permissible Speed	n_2	rpm	5~18	200
Torsional Backlash		arcmin	5~18	≤ 1
Lost Motion		arcmin	5~18	2 (0.033°)
Repetitive Positioning Accuracy		arcsec	5~18	± 10 (0.0028°)
Permissible Thrust Load	F_{2aB}	N	5~18	1,200
Permissible Moment Load		Nm	5~18	24
Runout of Output Table Surface		mm	5~18	0.015
Runout of Output Table Inner / Outer Diameter		mm	5~18	0.015
Parallelism of Output Table		mm	5~18	0.025
Protection Class			5~18	IP 65
Weight ± 3%		kg	5~18	2.04

MODEL : KGT-110C

RATIO : 25, 50, 100 (2-Stage)



KGT

Unit: mm

Model Code	110C-2
A1	70, 75, 90
A2	M4, M5, M6
A3	50, 60, 70
A4	64, 70, 80

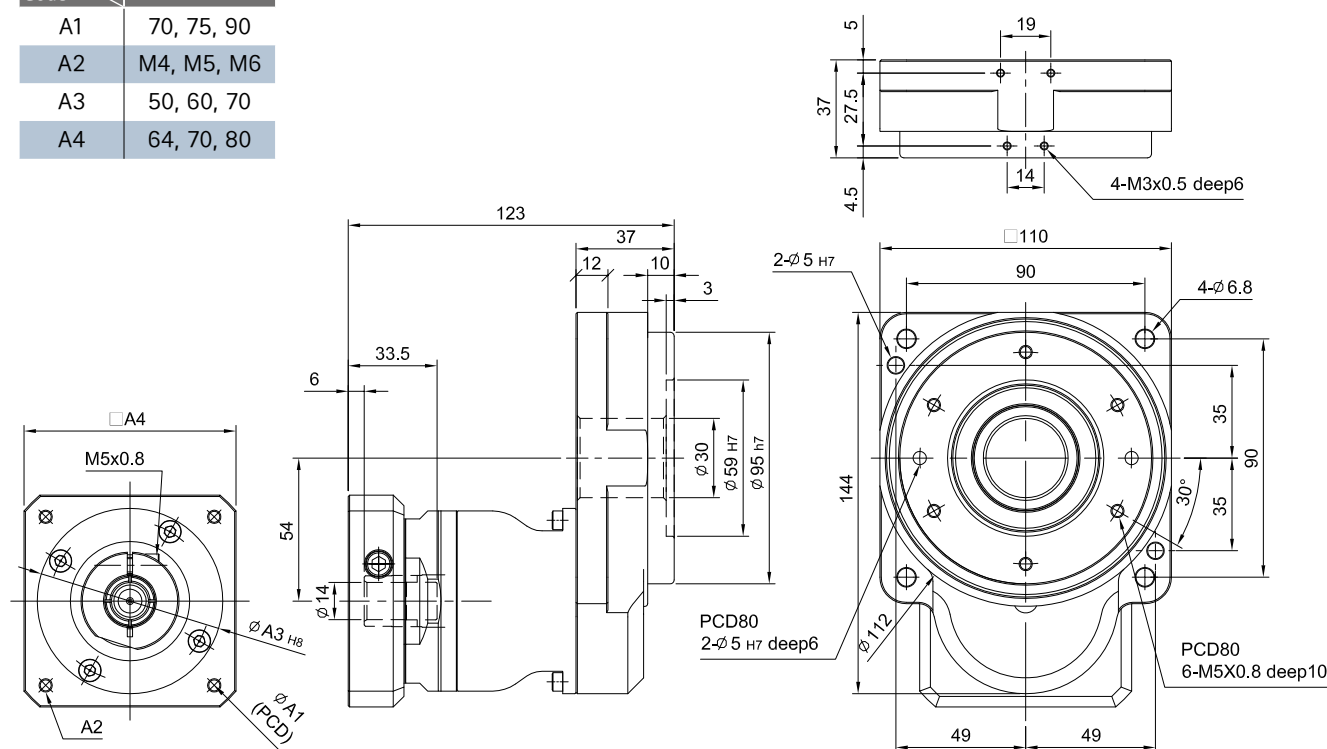

Characteristic		Unit	Ratio	KGT-110C-2
Output Table Supporting Bearing			25~100	Cross Roller Bearing
Rated Output Torque	T_{2N}	Nm	25	33
			50	26
			100	26
Max. Output Torque Emergency Stop Torque	T_{2NOT}	Nm	25~100	2 Time of Rated Output Torque
Inertia Moment		kg.m ²	25~100	$1,483 \times 10^{-6}$
Output Permissible Speed	n_2	rpm	25~100	200
Torsional Backlash		arcmin	25~100	≤ 2
Lost Motion		arcmin	25~100	3 (0.05°)
Repetitive Positioning Accuracy		arcsec	25~100	± 15 (0.0042°)
Permissible Thrust Load	F_{2aB}	N	25~100	1,200
Permissible Moment Load		Nm	25~100	24
Runout of Output Table Surface		mm	25~100	0.015
Runout of Output Table Inner / Outer Diameter		mm	25~100	0.015
Parallelism of Output Table		mm	25~100	0.025
Protection Class			25~100	IP 65
Weight ± 3%		kg	25~100	3.51

MODEL : KGT-135C

RATIO : 5, 10, 18 (1-Stage)



Unit: mm

Model Code	135C-1
A1	70, 75, 90
A2	M4, M5, M6
A3	50, 60, 70
A4	64, 70, 80
A5	14 ~ 19
A6	95 (98)

* ()는 감속비 1/18인 경우

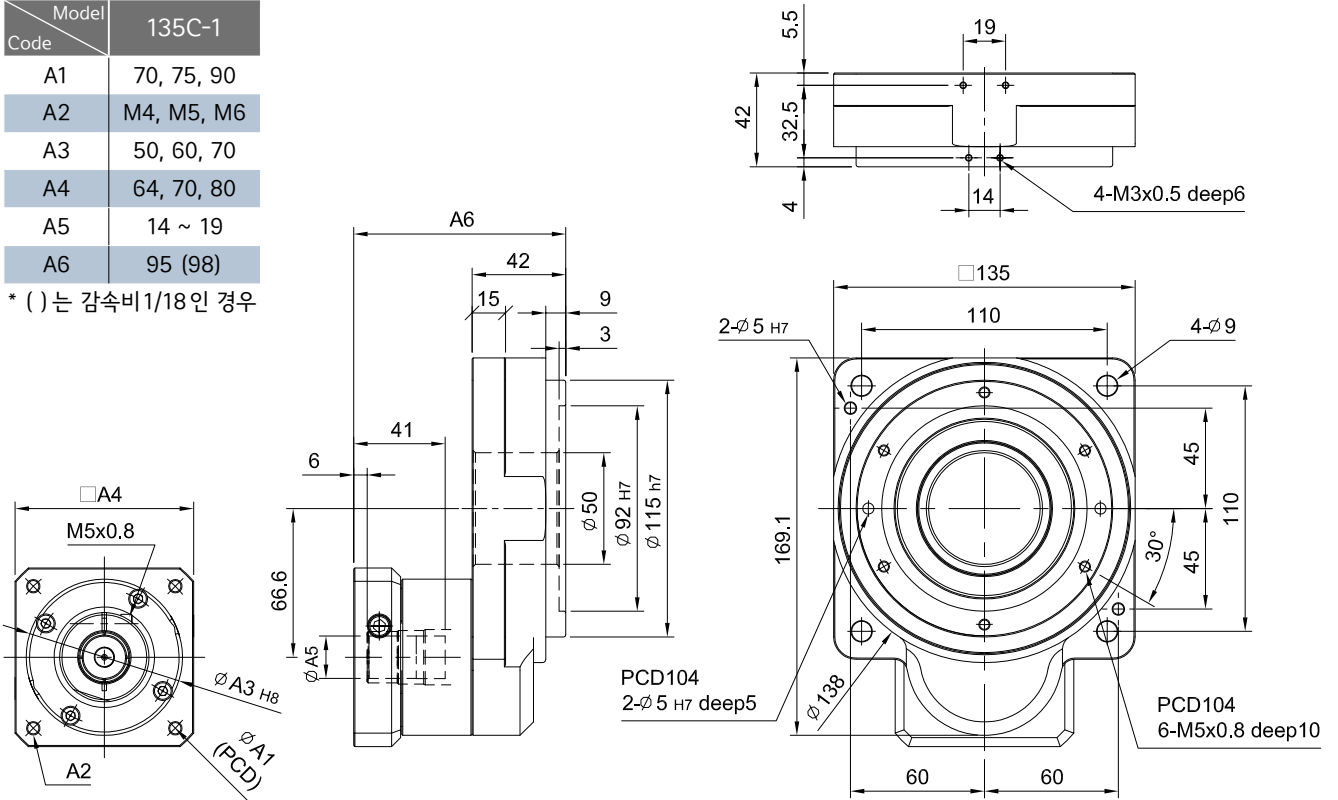

Characteristic		Unit	Ratio	KGT-135C-1
Output Table Supporting Bearing			5~18	Cross Roller Bearing
Rated Output Torque	T_{2N}	Nm	5	43
			10	34
			18	25
Max. Output Torque Emergency Stop Torque	T_{2NOT}	Nm	5~18	2 Time of Rated Output Torque
Inertia Moment		kg.m ²	5~18	$2,772 \times 10^{-6}$
Output Permissible Speed	n_2	rpm	5~18	200
Torsional Backlash		arcmin	5~18	≤ 1
Lost Motion		arcmin	5~18	2 (0.033°)
Repetitive Positioning Accuracy		arcsec	5~18	± 10 (0.0028°)
Permissible Thrust Load	F_{2aB}	N	5~18	2,200
Permissible Moment Load		Nm	5~18	45
Runout of Output Table Surface		mm	5~18	0.015
Runout of Output Table Inner / Outer Diameter		mm	5~18	0.015
Parallelism of Output Table		mm	5~18	0.025
Protection Class			5~18	IP 65
Weight ± 3%		kg	5~18	3.13

MODEL : KGT-135C

RATIO : 25, 50, 100 (2-Stage)



KGT

Unit: mm

Model Code	135C-2
A1	70, 75, 90
A2	M4, M5, M6
A3	50, 60, 70
A4	64, 70, 80
A5	14 ~ 19
A6	33.5, 41.5
A7	6
A8	128, 136

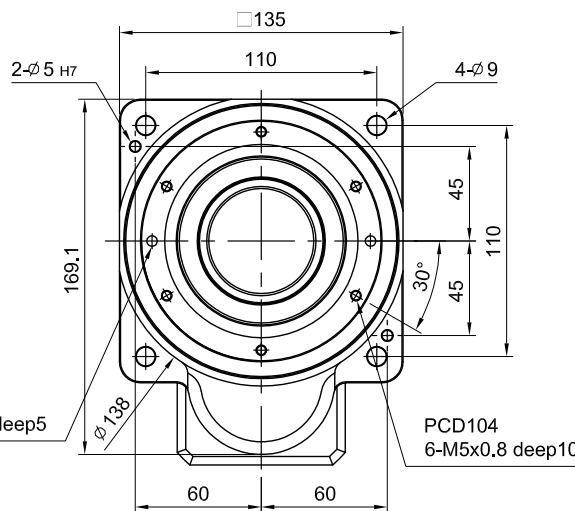
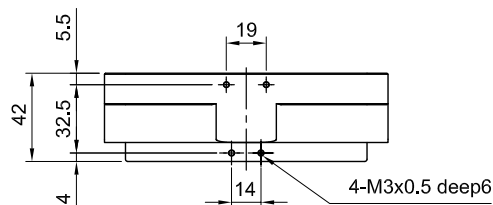
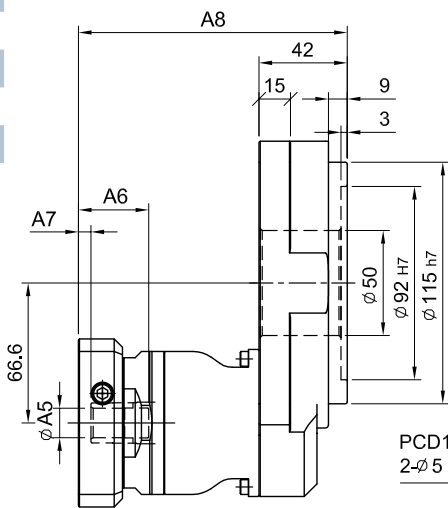
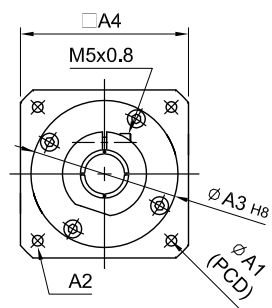

Characteristic		Unit	Ratio	KGT-135C-2
Output Table Supporting Bearing			25~100	Cross Roller Bearing
Rated Output Torque	T_{2N}	Nm	25	43
			50	34
			100	34
Max. Output Torque Emergency Stop Torque	T_{2NOT}	Nm	25~100	2 Time of Rated Output Torque
Inertia Moment		kg.m ²	25~100	$2,772 \times 10^{-6}$
Output Permissible Speed	n_2	rpm	25~100	200
Torsional Backlash		arcmin	25~100	≤ 2
Lost Motion		arcmin	25~100	3 (0.05°)
Repetitive Positioning Accuracy		arcsec	25~100	± 15 (0.0042°)
Permissible Thrust Load	F_{2aB}	N	25~100	2,200
Permissible Moment Load		Nm	25~100	45
Runout of Output Table Surface		mm	25~100	0.015
Runout of Output Table Inner / Outer Diameter		mm	25~100	0.015
Parallelism of Output Table		mm	25~100	0.025
Protection Class			25~100	IP 65
Weight $\pm 3\%$		kg	25~100	4.21

MODEL : KGT-200C

RATIO : 5, 10, 18 (1-Stage)

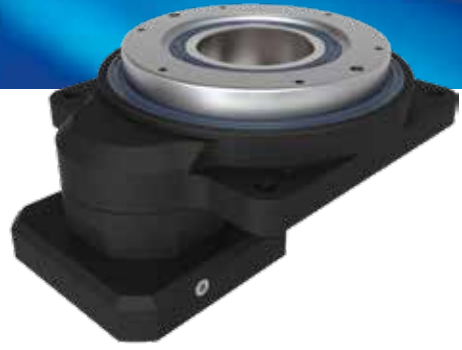

Unit: mm

Model Code	200C-1
A1	90, 100, 115, 145
A2	M5, M6, M8
A3	70, 80, 95, 110
A4	92, 110, 130
A5	19 ~ 24
A6	44.5, 57.5
A7	8.5, 7.5
A8	113.5, 126.5 (127.5)

* () 는 감속비 1/18 인 경우

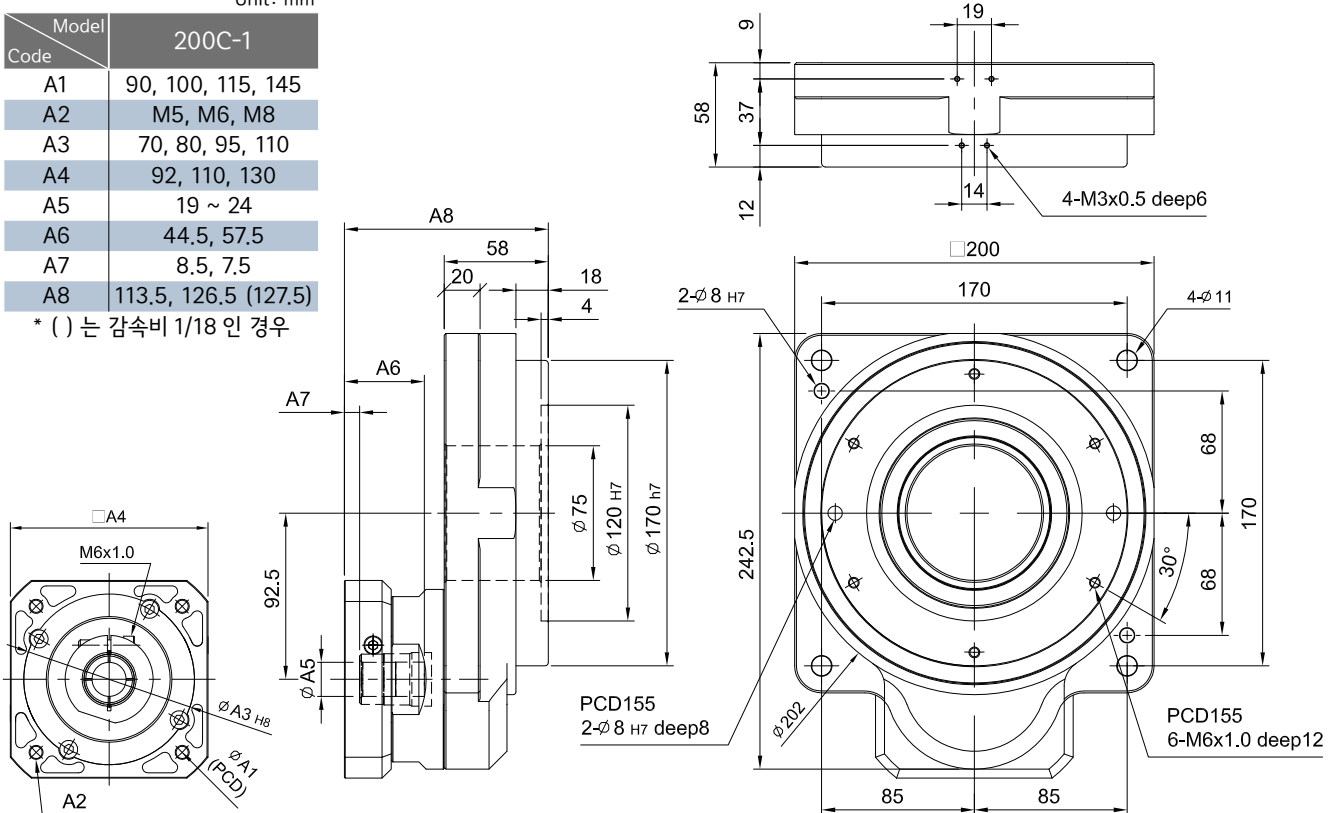

Characteristic		Unit	Ratio	KGT-200C-1
Output Table Supporting Bearing			5~18	Cross Roller Bearing
Rated Output Torque	T_{2N}	Nm	5	142
			10	112
			18	85
Max. Output Torque Emergency Stop Torque	T_{2NOT}	Nm	5~18	2 Time of Rated Output Torque
Inertia Moment		kg.m ²	5~18	$27,619 \times 10^{-6}$
Output Permissible Speed	n_2	rpm	5~18	200
Torsional Backlash		arcmin	5~18	≤ 1
Lost Motion		arcmin	5~18	2 (0.033°)
Repetitive Positioning Accuracy		arcsec	5~18	± 10 (0.0028°)
Permissible Thrust Load	F_{2aB}	N	5~18	4,000
Permissible Moment Load		Nm	5~18	80
Runout of Output Table Surface		mm	5~18	0.02
Runout of Output Table Inner / Outer Diameter		mm	5~18	0.02
Parallelism of Output Table		mm	5~18	0.03
Protection Class			5~18	IP 65
Weight ± 3%		kg	5~18	8.66

MODEL : KGT-200C

RATIO : 25, 50, 100 (2-Stage)

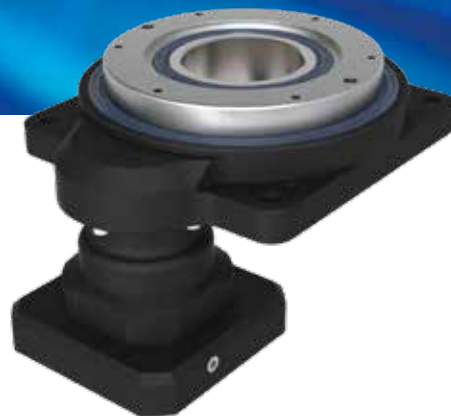

KGT

Unit: mm

Model Code	200C-2
A1	90, 100, 115, 145
A2	M5, M6, M8
A3	70, 80, 95, 110
A4	92, 110, 130

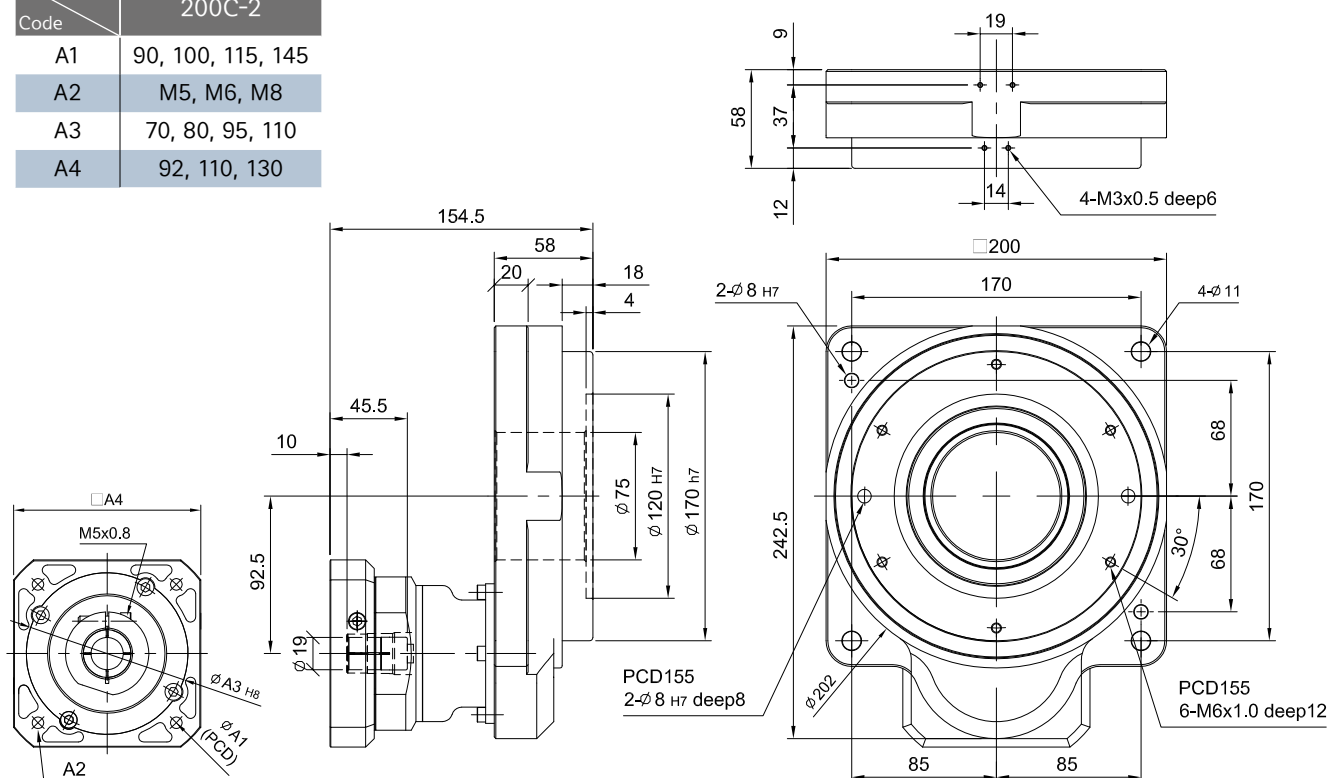

Characteristic		Unit	Ratio	KGT-200C-2
Output Table Supporting Bearing			25~100	Cross Roller Bearing
Rated Output Torque	T_{2N}	Nm	25	142
			50	112
			100	112
Max. Output Torque Emergency Stop Torque	T_{2NOT}	Nm	25~100	2 Time of Rated Output Torque
Inertia Moment		kg.m ²	25~100	$27,619 \times 10^{-6}$
Output Permissible Speed	n_2	rpm	25~100	200
Torsional Backlash		arcmin	25~100	≤ 2
Lost Motion		arcmin	25~100	3 (0.05°)
Repetitive Positioning Accuracy		arcsec	25~100	± 15 (0.0042°)
Permissible Thrust Load	F_{2aB}	N	25~100	4,000
Permissible Moment Load		Nm	25~100	80
Runout of Output Table Surface		mm	25~100	0.02
Runout of Output Table Inner / Outer Diameter		mm	25~100	0.02
Parallelism of Output Table		mm	25~100	0.03
Protection Class			25~100	IP 65
Weight ± 3%		kg	25~100	10.3

MODEL : KGT-60H

RATIO : 10, 18 (1-Stage)

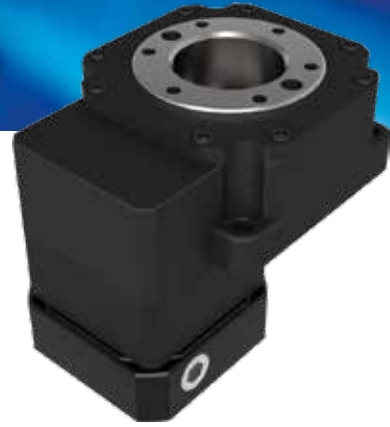

Unit: mm

Model Code	60H-1
A1	46, 63, 60
A2	M3, M4, M5
A3	30, 40, 50
A4	46, 55

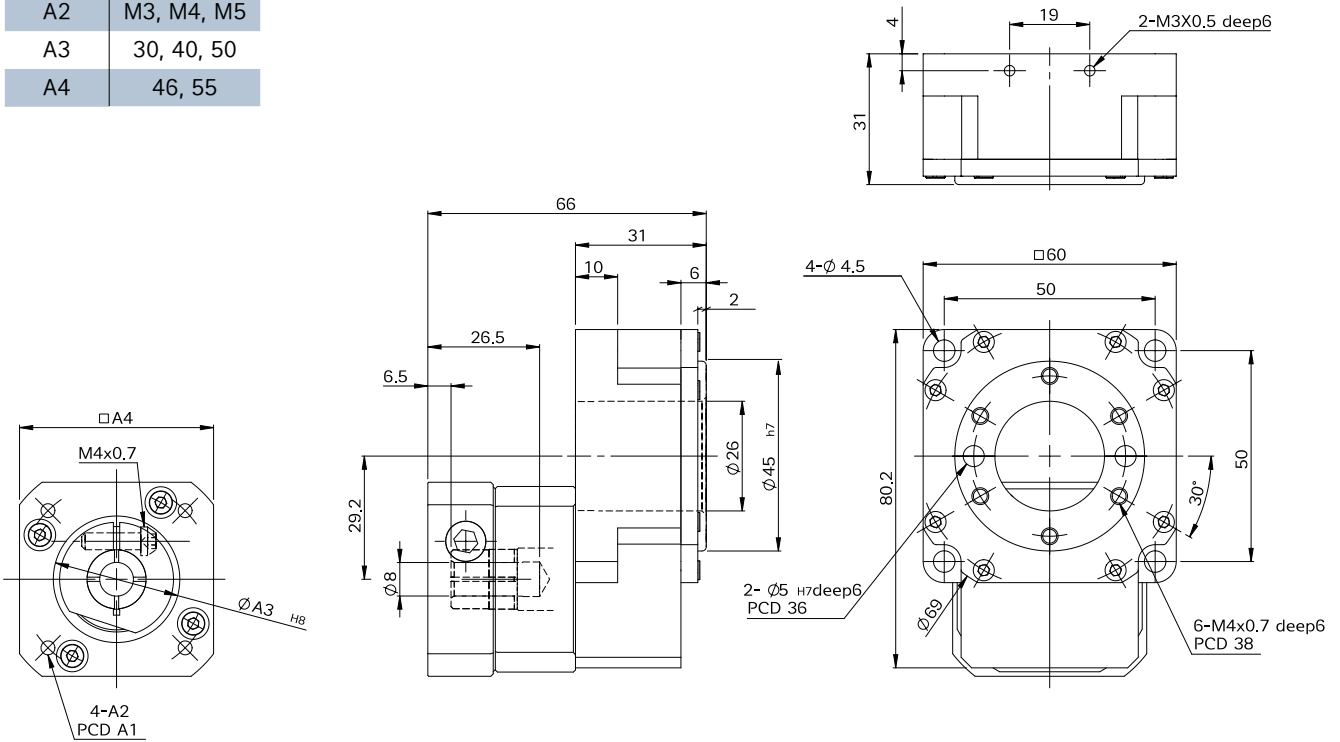

Characteristic		Unit	Ratio	KGT-60H-1
Output Table Supporting Bearing			10~18	Ball Bearing
Rated Output Torque	T_{2N}	Nm	10	4
			18	3
Max. Output Torque Emergency Stop Torque	T_{2NOT}	Nm	10~18	2 Time of Rated Output Torque
Inertia Moment		kg.m ²	10~18	777×10^{-7}
Output Permissible Speed	n_2	rpm	10~18	300
Torsional Backlash		arcmin	10~18	≤ 1
Lost Motion		arcmin	10~18	2 (0.033°)
Repetitive Positioning Accuracy		arcsec	10~18	± 10 (0.0028°)
Permissible Thrust Load	F_{2aB}	N	10~18	350
Permissible Moment Load		Nm	10~18	7
Runout of Output Table Surface		mm	10~18	0.01
Runout of Output Table Inner / Outer Diameter		mm	10~18	0.01
Parallelism of Output Table		mm	10~18	0.02
Protection Class			10~18	IP 65
Weight ± 3%		kg	10~18	0.54

MODEL : KGT-60H

RATIO : 50, 100 (2-Stage)



KGT

Unit: mm

Model Code	60H-2
A1	46, 63, 60
A2	M3, M4, M5
A3	30, 40, 50
A4	46, 55

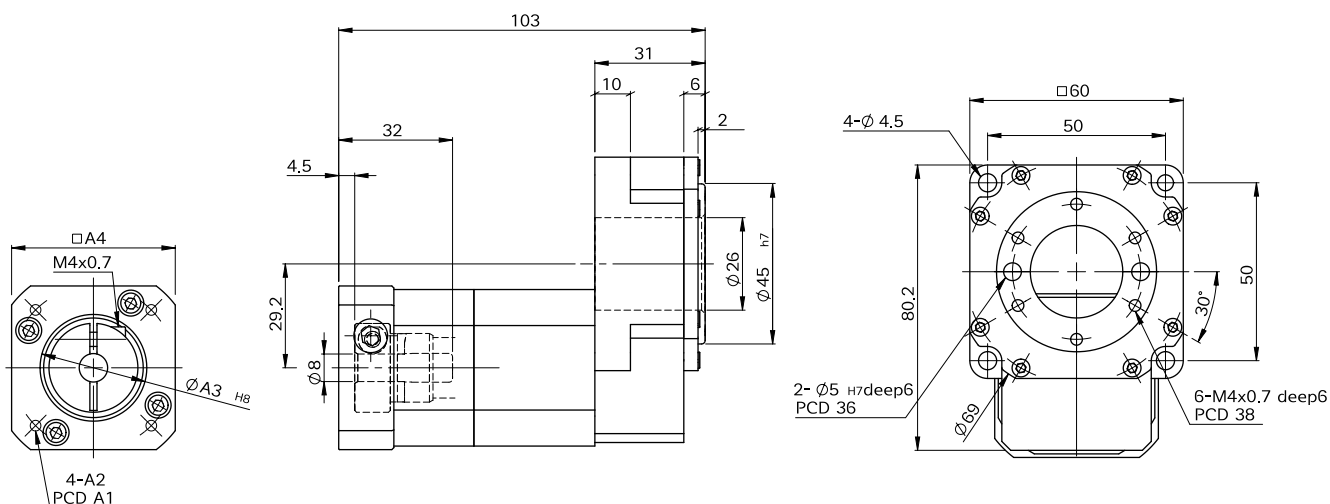
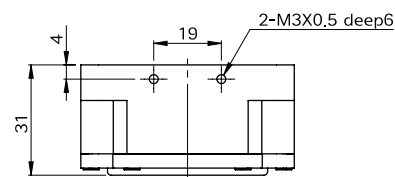

Characteristic		Unit	Ratio	KGT-60H-2
Output Table Supporting Bearing			50~100	Ball Bearing
Rated Output Torque	T_{2N}	Nm	50	4
			100	4
Max. Output Torque Emergency Stop Torque	T_{2NOT}	Nm	50~100	2 Time of Rated Output Torque
Inertia Moment		kg.m ²	50~100	777×10^{-7}
Output Permissible Speed	n_2	rpm	50~100	300
Torsional Backlash		arcmin	50~100	≤ 2
Lost Motion		arcmin	50~100	3 (0.05°)
Repetitive Positioning Accuracy		arcsec	50~100	± 15 (0.0042°)
Permissible Thrust Load	F_{2aB}	N	50~100	350
Permissible Moment Load		Nm	50~100	7
Runout of Output Table Surface		mm	50~100	0.01
Runout of Output Table Inner / Outer Diameter		mm	50~100	0.01
Parallelism of Output Table		mm	50~100	0.02
Protection Class			50~100	IP 65
Weight $\pm 3\%$		kg	50~100	1.1

MODEL : KGT-85H

RATIO : 10, 18 (1-Stage)



Unit: mm

Model Code	85H-1
A1	46, 63, 70
A2	M3, M4, M5
A3	30, 40, 50
A4	46, 55, 60
A5	77.5 (78.5)

* () 는 감속비 1/18인 경우

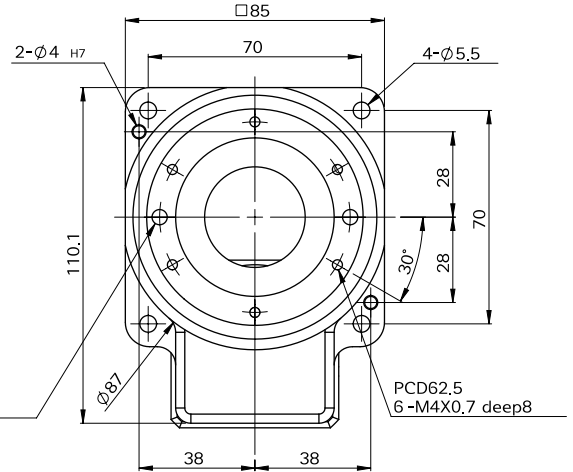
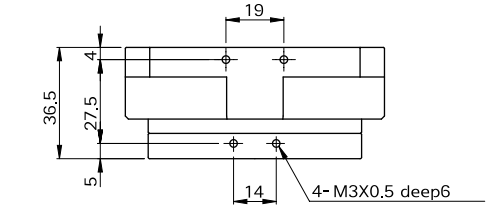
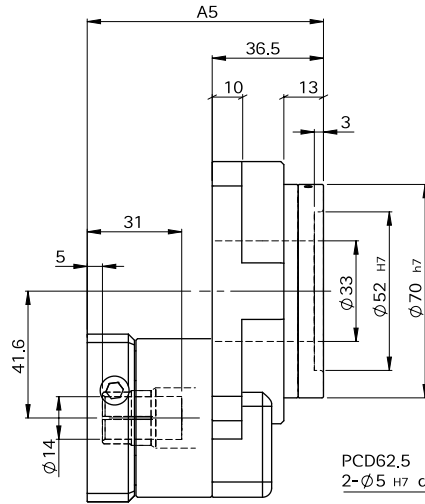
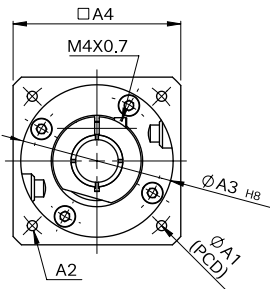

Characteristic		Unit	Ratio	KGT-85H-1
Output Table Supporting Bearing			10~18	Cross Roller Bearing
Rated Output Torque	T _{2N}	Nm	10	14
			18	10
Max. Output Torque Emergency Stop Torque	T _{2NOT}	Nm	10~18	2 Time of Rated Output Torque
Inertia Moment		kg.m ²	10~18	1,203 x 10 ⁻⁶
Output Permissible Speed	n ₂	rpm	10~18	200
Torsional Backlash		arcmin	10~18	≤ 1
Lost Motion		arcmin	10~18	2 (0.033°)
Repetitive Positioning Accuracy		arcsec	10~18	± 10 (0.0028°)
Permissible Thrust Load	F _{2aB}	N	10~18	900
Permissible Moment Load		Nm	10~18	18
Runout of Output Table Surface		mm	10~18	0.01
Runout of Output Table Inner / Outer Diameter		mm	10~18	0.01
Parallelism of Output Table		mm	10~18	0.02
Protection Class			10~18	IP 65
Weight ± 3%		kg	10~18	1.1

MODEL : KGT-85H

RATIO : 50, 100 (2-Stage)

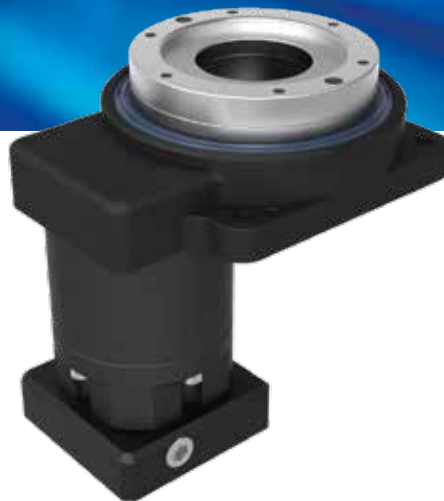

KGT

Unit: mm

Model Code	85H-2
A1	46, 63, 70
A2	M3, M4, M5
A3	30, 40, 50
A4	46, 55, 60

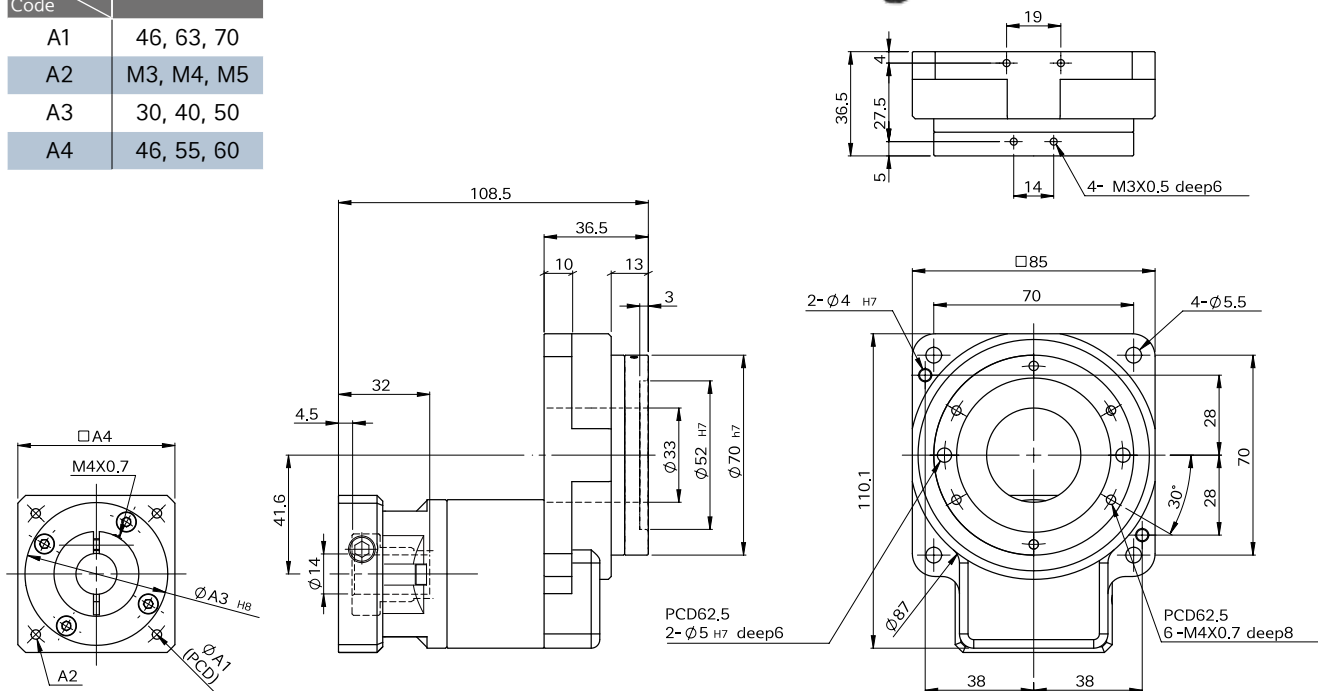

Characteristic		Unit	Ratio	KGT-85H-2
Output Table Supporting Bearing			50~100	Cross Roller Bearing
Rated Output Torque	T_{2N}	Nm	50	14
			100	14
Max. Output Torque Emergency Stop Torque	T_{2NOT}	Nm	50~100	2 Time of Rated Output Torque
Inertia Moment		kg.m ²	50~100	1,203 x 10 ⁻⁶
Output Permissible Speed	n_2	rpm	50~100	200
Torsional Backlash		arcmin	50~100	≤ 2
Lost Motion		arcmin	50~100	3 (0.05°)
Repetitive Positioning Accuracy		arcsec	50~100	± 15 (0.0042°)
Permissible Thrust Load	F_{2aB}	N	50~100	900
Permissible Moment Load		Nm	50~100	18
Runout of Output Table Surface		mm	50~100	0.01
Runout of Output Table Inner / Outer Diameter		mm	50~100	0.01
Parallelism of Output Table		mm	50~100	0.02
Protection Class			50~100	IP 65
Weight ± 3%		kg	50~100	1.7

MODEL : KGT-110H

RATIO : 10, 18 (1-Stage)

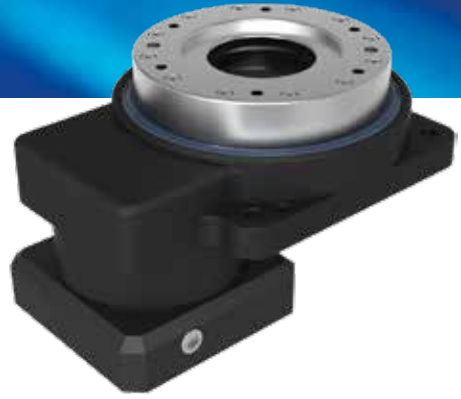

Unit: mm

Model Code	110H-1
A1	70, 75, 90
A2	M4, M5, M6
A3	50, 60, 70
A4	64, 70, 80
A5	88.5 (90.5)

* ()는 감속비 1/18인 경우

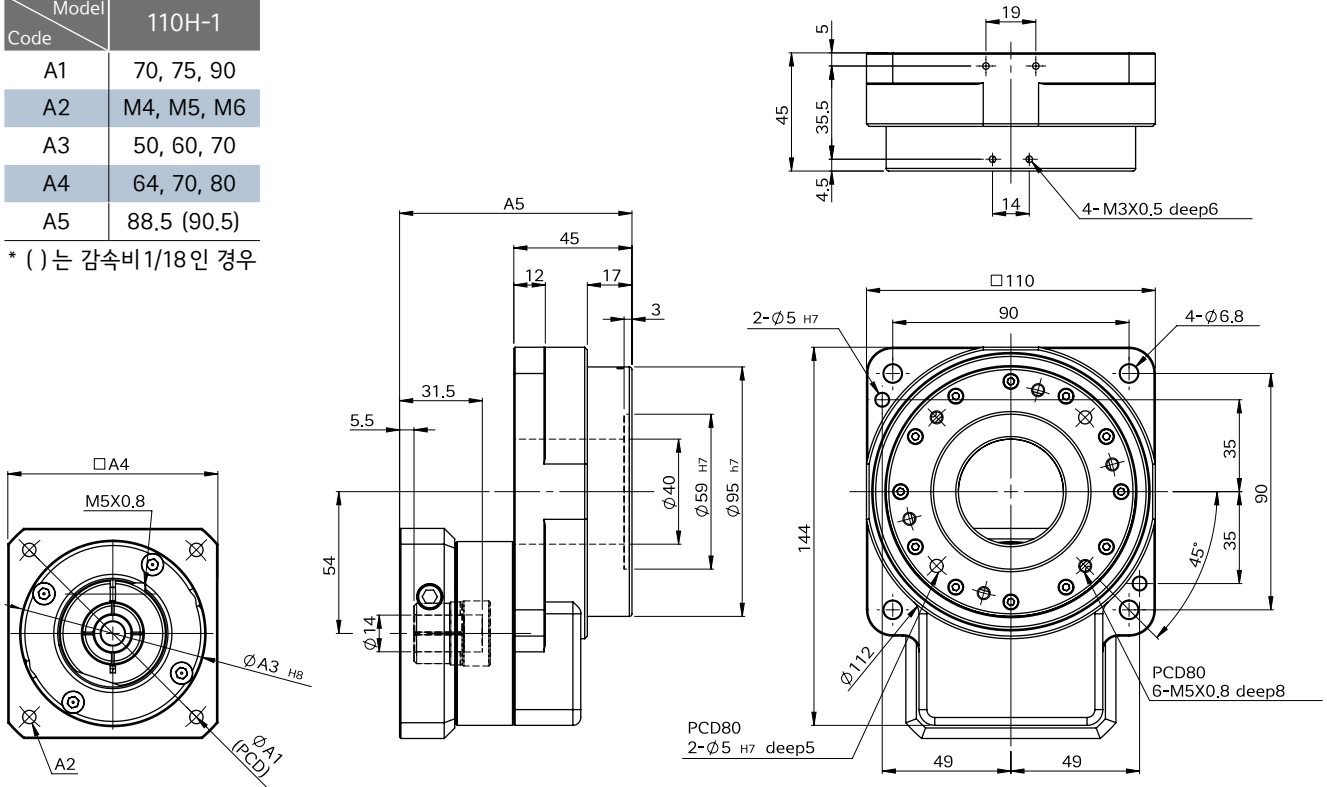

Characteristic		Unit	Ratio	KGT-110H-1
Output Table Supporting Bearing			10~18	Cross Roller Bearing
Rated Output Torque	T _{2N}	Nm	10	26
			18	19
Max. Output Torque Emergency Stop Torque	T _{2NOT}	Nm	10~18	2 Time of Rated Output Torque
Inertia Moment		kg.m ²	10~18	1,483 x 10 ⁻⁶
Output Permissible Speed	n ₂	rpm	10~18	200
Torsional Backlash		arcmin	10~18	≤ 1
Lost Motion		arcmin	10~18	2 (0.033°)
Repetitive Positioning Accuracy		arcsec	10~18	± 10 (0.0028°)
Permissible Thrust Load	F _{2aB}	N	10~18	1,200
Permissible Moment Load		Nm	10~18	24
Runout of Output Table Surface		mm	10~18	0.015
Runout of Output Table Inner / Outer Diameter		mm	10~18	0.015
Parallelism of Output Table		mm	10~18	0.025
Protection Class			10~18	IP 65
Weight ± 3%		kg	10~18	2.04

MODEL : KGT-110H

RATIO : 50, 100 (2-Stage)



KGT

Unit: mm

Model Code	110H-2
A1	70, 75, 90
A2	M4, M5, M6
A3	50, 60, 70
A4	64, 70, 80

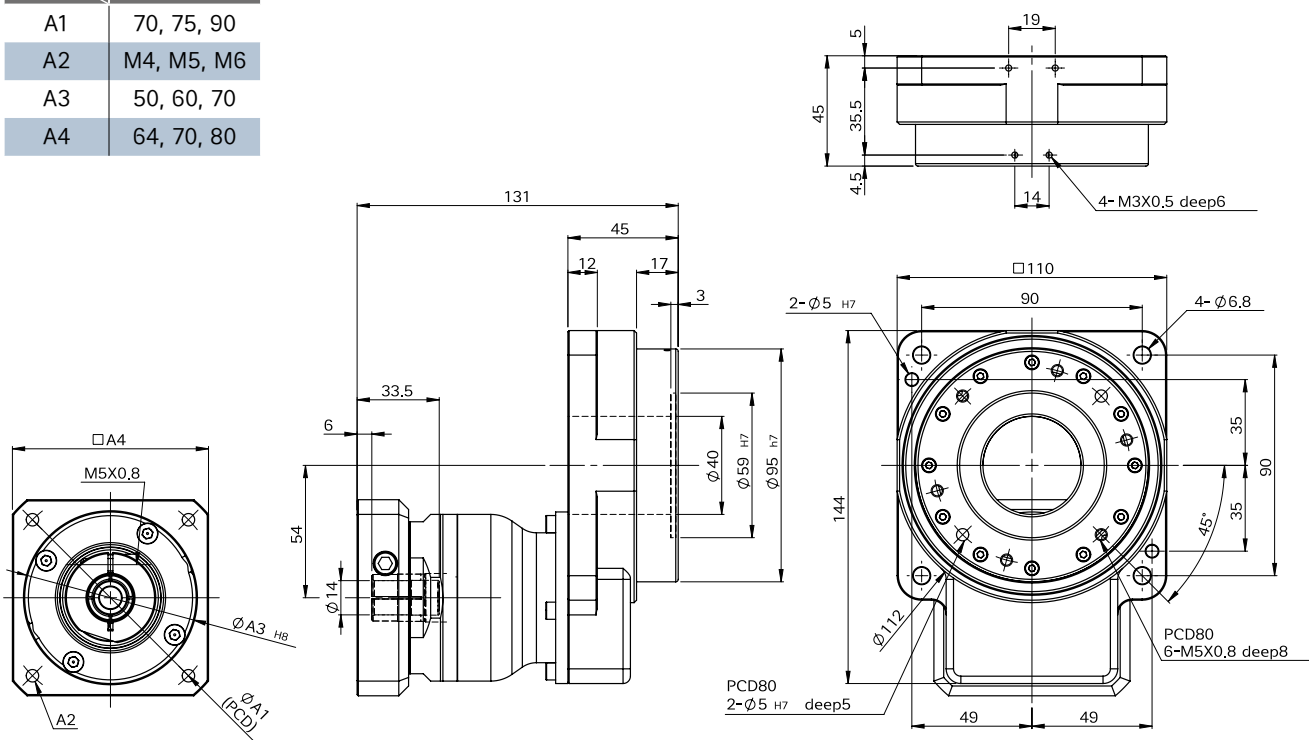

Characteristic		Unit	Ratio	KGT-110H-2
Output Table Supporting Bearing			50~100	Cross Roller Bearing
Rated Output Torque	T_{2N}	Nm	50	26
			100	26
Max. Output Torque Emergency Stop Torque	T_{2NOT}	Nm	50~100	2 Time of Rated Output Torque
Inertia Moment		kg.m ²	50~100	$1,483 \times 10^{-6}$
Output Permissible Speed	n_2	rpm	50~100	200
Torsional Backlash		arcmin	50~100	≤ 2
Lost Motion		arcmin	50~100	3 (0.05°)
Repetitive Positioning Accuracy		arcsec	50~100	± 15 (0.0042°)
Permissible Thrust Load	F_{2aB}	N	50~100	1,200
Permissible Moment Load		Nm	50~100	24
Runout of Output Table Surface		mm	50~100	0.015
Runout of Output Table Inner / Outer Diameter		mm	50~100	0.015
Parallelism of Output Table		mm	50~100	0.025
Protection Class			50~100	IP 65
Weight ± 3%		kg	50~100	3.51

MODEL : KGT-135H

RATIO : 10, 18 (1-Stage)

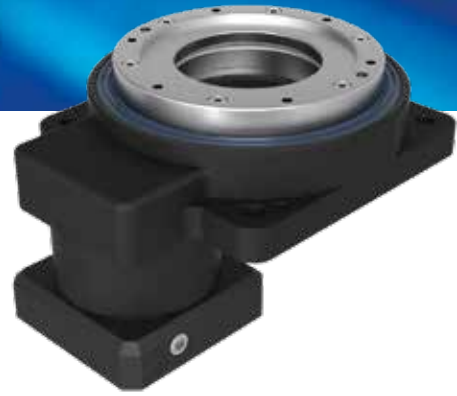

Unit: mm

Model Code	135H-1
A1	70, 75, 90
A2	M4, M5, M6
A3	50, 60, 70
A4	64, 70, 80
A5	101 (104)

* ()는 감속비 1/18인 경우

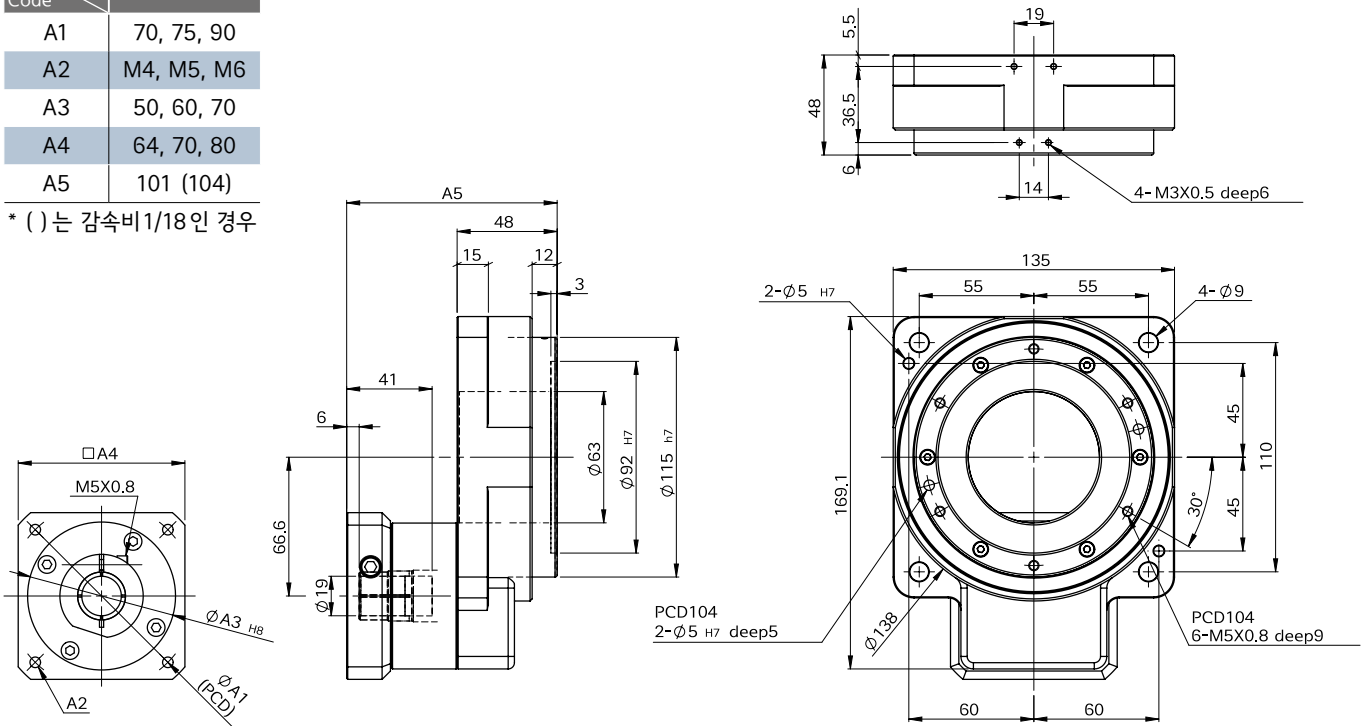

Characteristic	Unit	Ratio	KGT-135H-1	
Output Table Supporting Bearing		10~18	Cross Roller Bearing	
Rated Output Torque	T_{2N}	Nm	10	34
			18	25
Max. Output Torque Emergency Stop Torque	T_{2NOT}	Nm	10~18	2 Time of Rated Output Torque
Inertia Moment		kg.m ²	10~18	$2,772 \times 10^{-6}$
Output Permissible Speed	n_2	rpm	10~18	200
Torsional Backlash		arcmin	10~18	≤ 1
Lost Motion		arcmin	10~18	2 (0.033°)
Repetitive Positioning Accuracy		arcsec	10~18	± 10 (0.0028°)
Permissible Thrust Load	F_{2aB}	N	10~18	2,200
Permissible Moment Load		Nm	10~18	45
Runout of Output Table Surface		mm	10~18	0.015
Runout of Output Table Inner / Outer Diameter		mm	10~18	0.015
Parallelism of Output Table		mm	10~18	0.025
Protection Class			10~18	IP 65
Weight $\pm 3\%$		kg	10~18	3.13

MODEL : KGT-135H

RATIO : 50, 100 (2-Stage)

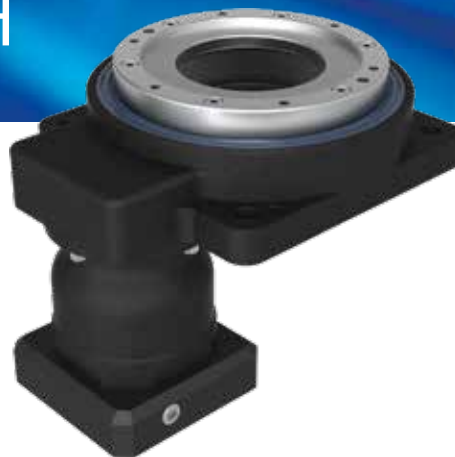

KGT

Unit: mm

Model Code	135H-2
A1	70, 75, 90
A2	M4, M5, M6
A3	50, 60, 70
A4	64, 70, 80

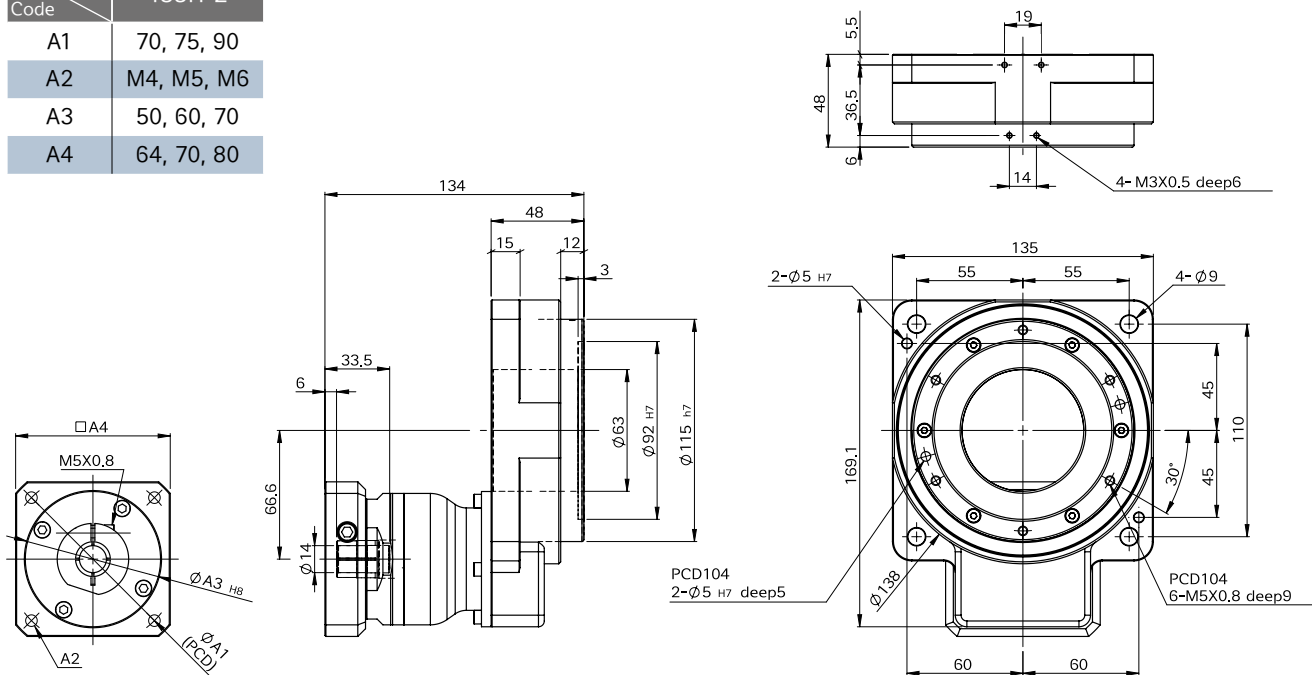

Characteristic		Unit	Ratio	KGT-135H-2
Output Table Supporting Bearing			50~100	Cross Roller Bearing
Rated Output Torque	T_{2N}	Nm	50	34
			100	34
Max. Output Torque Emergency Stop Torque	T_{2NOT}	Nm	50~100	2 Time of Rated Output Torque
Inertia Moment		kg.m ²	50~100	$2,772 \times 10^{-6}$
Output Permissible Speed	n_2	rpm	50~100	200
Torsional Backlash		arcmin	50~100	≤ 2
Lost Motion		arcmin	50~100	3 (0.05°)
Repetitive Positioning Accuracy		arcsec	50~100	± 15 (0.0042°)
Permissible Thrust Load	F_{2aB}	N	50~100	2,200
Permissible Moment Load		Nm	50~100	45
Runout of Output Table Surface		mm	50~100	0.015
Runout of Output Table Inner / Outer Diameter		mm	50~100	0.015
Parallelism of Output Table		mm	50~100	0.025
Protection Class			50~100	IP 65
Weight ± 3%		kg	50~100	4.21

MODEL : KGT-200H

RATIO : 10, 18 (1-Stage)

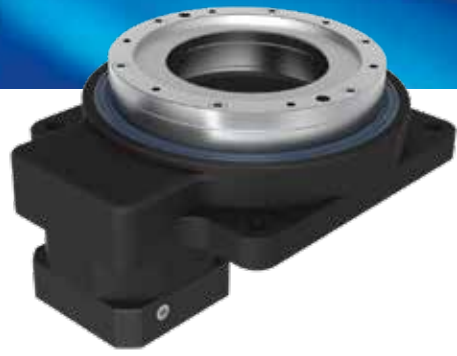

Unit: mm

Model Code	200H-1
A1	90, 100, 115, 145
A2	M5, M6, M8
A3	70, 80, 95, 110
A4	92, 110, 130
A5	19 ~ 24
A6	44.5, 57.5
A7	8.5, 7.5
A8	125.5, 138.5 (139.5)

* () 는 감속비 1/18 인 경우

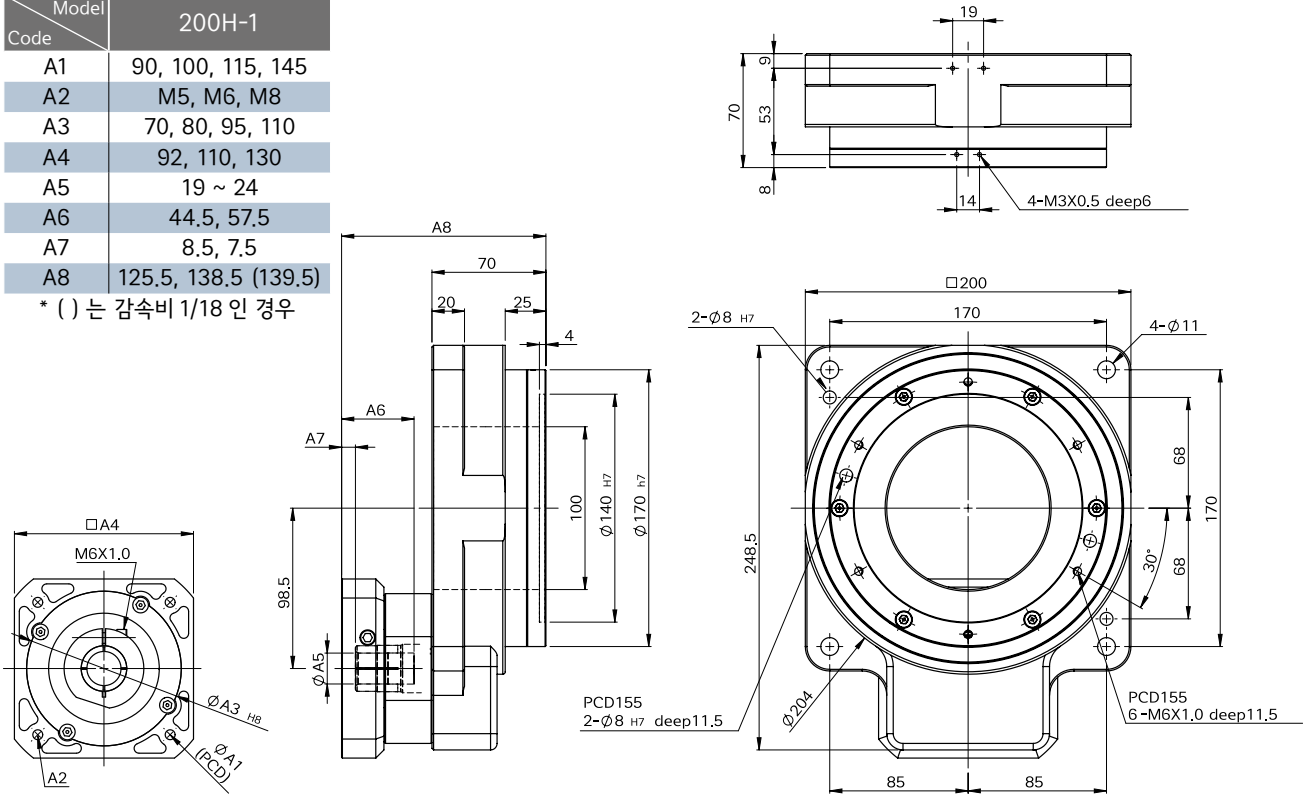

Characteristic		Unit	Ratio	KGT-200H-1
Output Table Supporting Bearing			10~18	Cross Roller Bearing
Rated Output Torque	T_{2N}	Nm	10	183
			18	128
Max. Output Torque Emergency Stop Torque	T_{2NOT}	Nm	10~18	2 Time of Rated Output Torque
Inertia Moment		kg.m ²	10~18	27,619 x 10 ⁻⁶
Output Permissible Speed	n_2	rpm	10~18	200
Torsional Backlash		arcmin	10~18	≤ 1
Lost Motion		arcmin	10~18	2 (0.033°)
Repetitive Positioning Accuracy		arcsec	10~18	± 10 (0.0028°)
Permissible Thrust Load	F_{2aB}	N	10~18	4,000
Permissible Moment Load		Nm	10~18	80
Runout of Output Table Surface		mm	10~18	0.02
Runout of Output Table Inner / Outer Diameter		mm	10~18	0.02
Parallelism of Output Table		mm	10~18	0.03
Protection Class			10~18	IP 65
Weight ± 3%		kg	10~18	9.7

MODEL : KGT-200H

RATIO : 50, 100 (2-Stage)

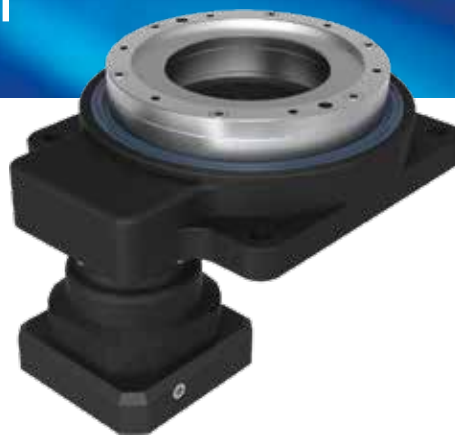

KGT

Unit: mm

Model Code	200H-2
A1	90, 100, 115, 145
A2	M5, M6, M8
A3	70, 80, 95, 110
A4	92, 110, 130

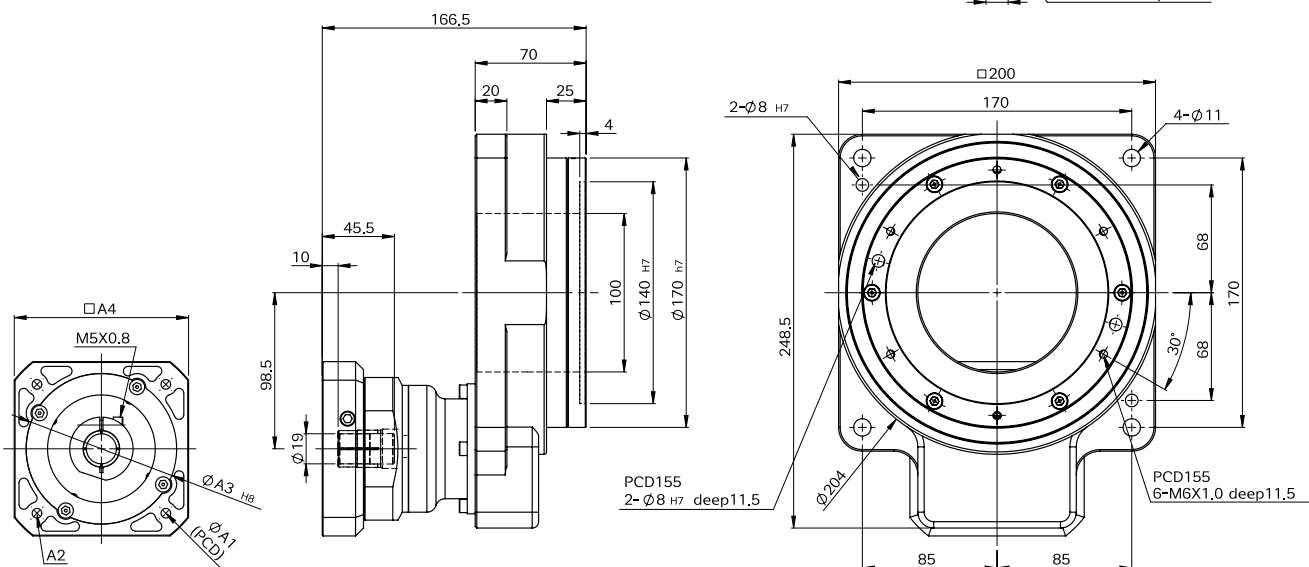
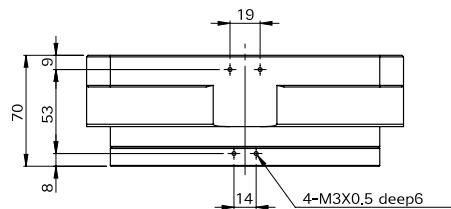

Characteristic		Unit	Ratio	KGT-200H-2
Output Table Supporting Bearing			50~100	Cross Roller Bearing
Rated Output Torque	T_{2N}	Nm	50	183
			100	183
Max. Output Torque Emergency Stop Torque	T_{2NOT}	Nm	50~100	2 Time of Rated Output Torque
Inertia Moment		kg.m ²	50~100	27,619 x 10 ⁻⁶
Output Permissible Speed	n_2	rpm	50~100	200
Torsional Backlash		arcmin	50~100	≤ 2
Lost Motion		arcmin	50~100	3 (0.05°)
Repetitive Positioning Accuracy		arcsec	50~100	± 15 (0.0042°)
Permissible Thrust Load	F_{2aB}	N	50~100	4,000
Permissible Moment Load		Nm	50~100	80
Runout of Output Table Surface		mm	50~100	0.02
Runout of Output Table Inner / Outer Diameter		mm	50~100	0.02
Parallelism of Output Table		mm	50~100	0.03
Protection Class			50~100	IP 65
Weight ± 3%		kg	50~100	11.3

MODEL : KGT-250H

RATIO : 10, 18 (1-Stage)

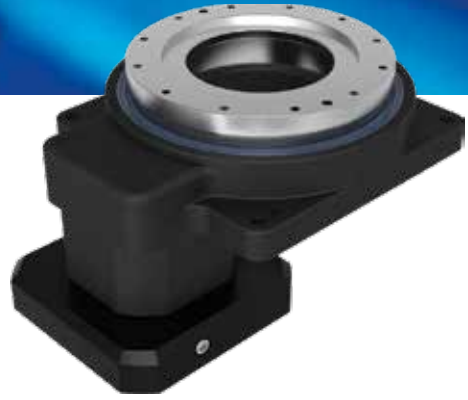

Unit: mm

Model Code	250H-1
A1	115, 145, 200
A2	M6, M8, M12
A3	95, 110, 114.3
A4	122, 130, 180

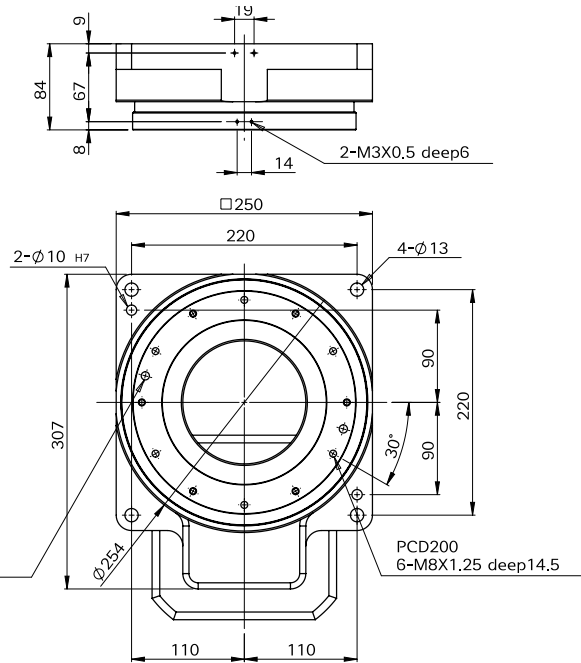
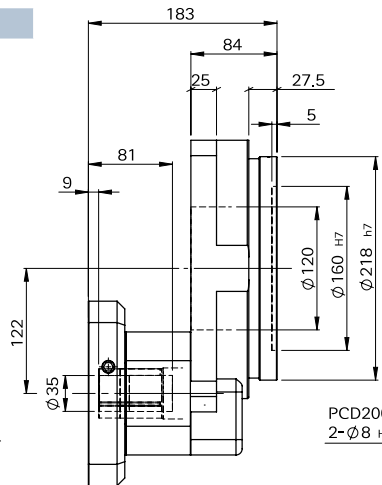
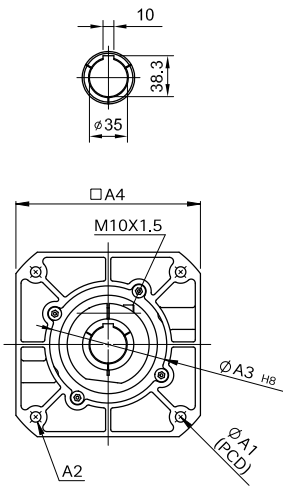

Characteristic		Unit	Ratio	KGT-250H-1
Output Table Supporting Bearing			10~18	Cross Roller Bearing
Rated Output Torque	T_{2N}	Nm	10	334
			18	234
Max. Output Torque Emergency Stop Torque	T_{2NOT}	Nm	10~18	2 Time of Rated Output Torque
Inertia Moment		kg.m ²	10~18	53,551 x 10 ⁻⁶
Output Permissible Speed	n_2	rpm	10~18	150
Torsional Backlash		arcmin	10~18	≤ 1
Lost Motion		arcmin	10~18	2 (0.033°)
Repetitive Positioning Accuracy		arcsec	10~18	± 10 (0.0028°)
Permissible Thrust Load	F_{2aB}	N	10~18	5,060
Permissible Moment Load		Nm	10~18	100
Runout of Output Table Surface		mm	10~18	0.025
Runout of Output Table Inner / Outer Diameter		mm	10~18	0.025
Parallelism of Output Table		mm	10~18	0.035
Protection Class			10~18	IP 65
Weight ± 3%		kg	10~18	20.1

Glossary

용어해설

Output Table Supporting Bearing

중공축 사용 베어링

This is the type of the bearing used for the output table.

Rated Output Torque [Nm]

감속기 허용 정격 토크이며 서보 적용시 허용 토크를 초과하지 않도록 한다.

This is the limit of mechanical strength of the speed reduction mechanism. Make sure that the applied torque, including the acceleration torque and load fluctuation, does not exceed the permissible torque.

Max. Output Torque / Emergency Stop Torque (T_{2NOT}) [Nm]

감속기의 최대허용 토크(T_{2NOT})를 지칭한다. 이 토크는 감속기 수명내 1,000번을 허용할 수 있으며 1,000번을 초과시 감속기 내부 부품이 손상될 수 있다.

$$T_{2NOT} = 2 T_{2B} \text{ (2 times of rated output torque)}$$

The emergency stop torque T_{2NOT} is the maximum permissible torque at the gearbox output end and must not be reached more than 1000 times during the service life of the gearbox. It must never be exceeded to prevent inside parts from damage. $T_{2NOT} = 2 T_{2B}$ (2 times of rated output torque)

Inertia Moment [$\text{kg}\cdot\text{m}^2$]

감속기 구성부의 관성모멘트

This is the total sum of the inertial moment of the speed reduction mechanism converted to a moment on the output table.

Output Permissible Speed [rpm]

출력 허용 속도

This is the output table speed that can be tolerated by the mechanical strength of the speed reduction mechanism.

Lost Motion [arcmin]

임의 위치에서의 정방향의 위치 결정 정지점과 역방향의 위치 결정 정지점과의 위치 오차

This is the difference in stopped angles achieved when the output table is positioned to the same position in the forward and reverse directions.

Repetitive Positioning Accuracy [arcsec]

동일한 방향으로 동일한 위치를 반복해서 같은 조건으로 측정하여 나온 정도

This is a value indicating the degree of error that generates when positioning is performed repeatedly to the same position in the same direction.

Permissible Thrust Load [N]

축하중을 받는 출력 테이블의 스러스트 하중 허용 값

This is the permissible value of thrust load applied to the output table in the axial direction.

Permissible Moment Load [Nm]

출력 테이블에 발생하는 편심의 모멘트 하중 허용 값

When a load is applied to a position away from the center of the output table, the output table receives a tilting force. The permissible moment load refers to the permissible value of moment load calculated by the eccentricity from the center by the applied load.

Runout of Output Table Surface [mm]

무부하 운전시 출력단의 평면 조립면 편차 최대량

This is the max. value of runout of the installation surface of the output table when the output table is rotated under no load.

Runout of Output Table Inner / Outer Diameter [mm]

무부하 운전시 출력 내경부와 외경부의 편차 최대값

This is the max. value of runout of the inner diameter or outer diameter of the table when the output table is rotated under no load.

Parallelism of Output Table [mm]

감속기 고정면과 출력 테이블 조립면의 기울기 정도

This is the inclination of the installation surface of the output table compared with the actuator installation surface on the equipment side.

Protection Class

방진, 방수 보호 등급 IP65 구조

Based on IP65, dustresistance and waterproofing regarding the degree of protection of the device is classified using a grade.

Weight [kg]

감속기 무게

Product weight.

Runout & Permissible Moment Load

Runout

KGT60/KGT85/KGT110/KGT135/KGT200

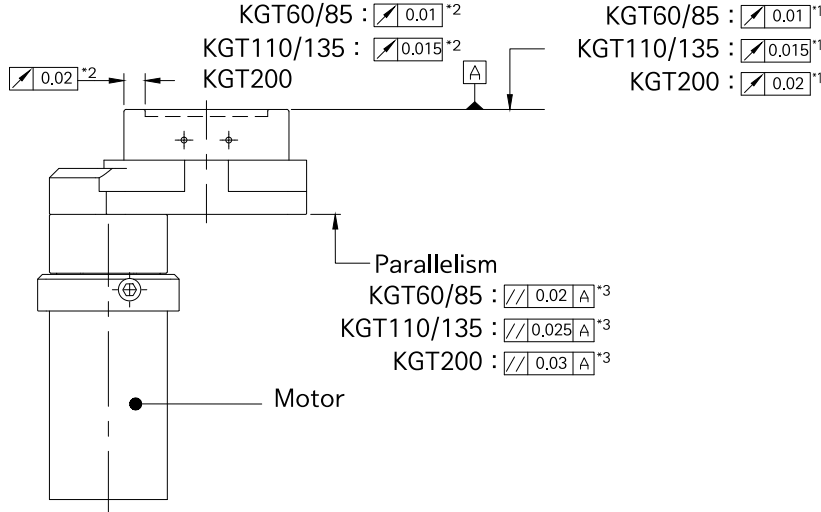

- *1. 무부하 회전시 출력 테이블 장착면의 흔들림(진동) 최대 값
- *2. 무부하 회전시 출력 테이블 내/외경의 흔들림(진동) 최대 값.
- *3. 감속기 설치면과 출력 테이블 장착면에 대한 평행도(설치면 기준)

Moment Load [Nm]로 거리별 허용무게 환산하기

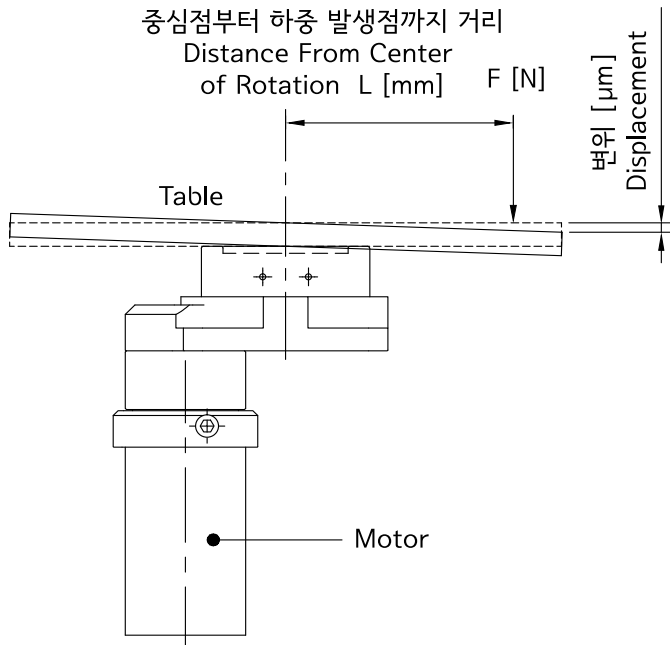

$$\text{Moment Load [Nm]} = 0.001 \times F(\text{N}) \times L(\text{mm})$$

예) KGT-85C Moment Load = 18Nm 측정거리 250mm

$$18 = 0.001 \times F \times 250 \quad F = 72\text{N (약 7.3kg)}$$

∴ KGT-85C 감속기는 250mm의 거리에서 7.3kg 까지만 허용된다는 의미이며, 초과 사용시 감속기 수명에 문제가 생길 수 있습니다.

모멘트하중에 따른 변위량 (참고치)

- * 출력테이블은 모멘트 하중을 받을때 변위가 발생합니다.
- * 그래프의 변위량은 모멘트 하중이 정(+), 역(-), 양방향으로 작용하였을 경우 출력 테이블의 회전 중심으로부터 거리(L)만큼 떨어진 위치에서의 변위입니다.
- * 모멘트 하중을 한방향으로 작용했을 경우 변위량은 약 50%가 됩니다.

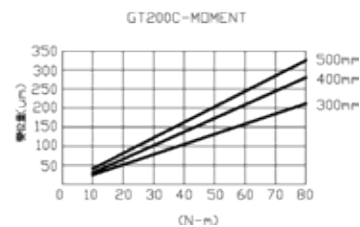
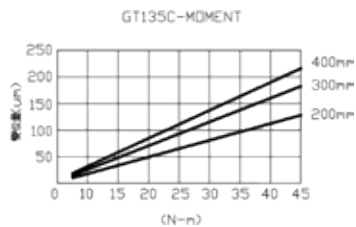
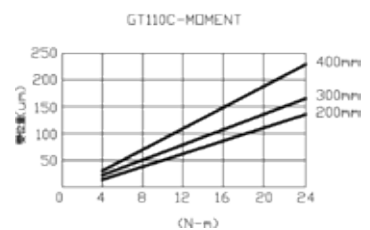
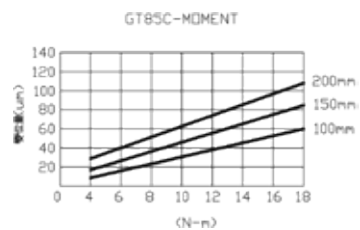
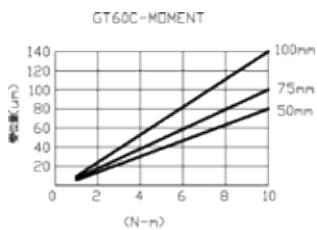
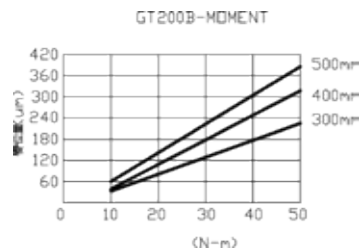
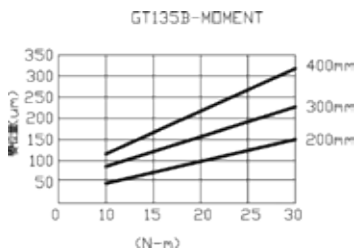
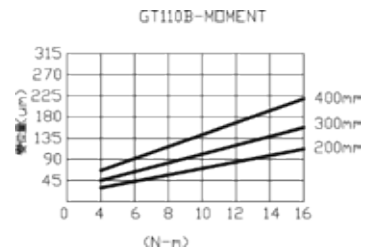
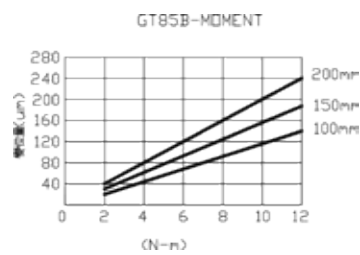
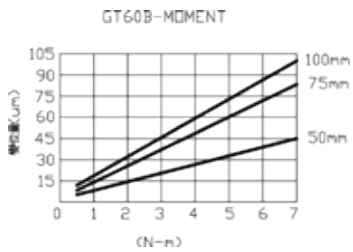

Applications

○ 모멘트 하중을 요하는 구조



○ 고정밀도의 위치 결정



○ Hollow Hole을 활용한 광학구조

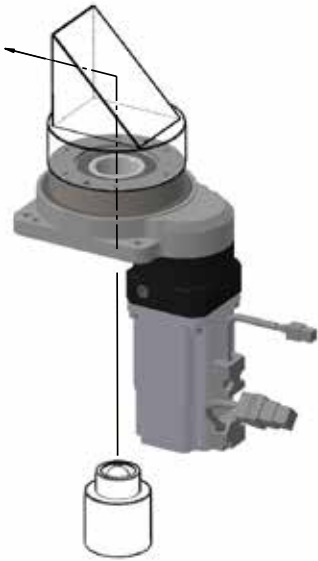

○ Hollow Hole을 활용한 Air 흡착구조

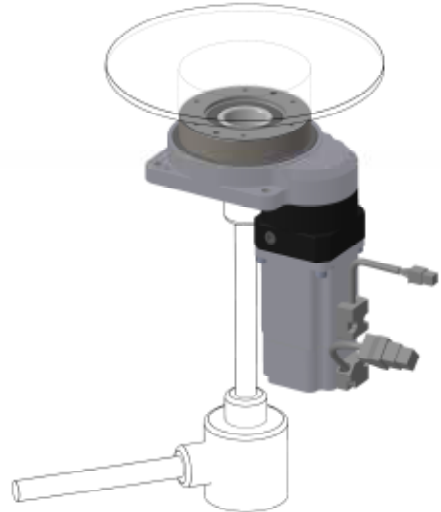

○ Hollow Hole을 활용한 고정밀도 위치결정

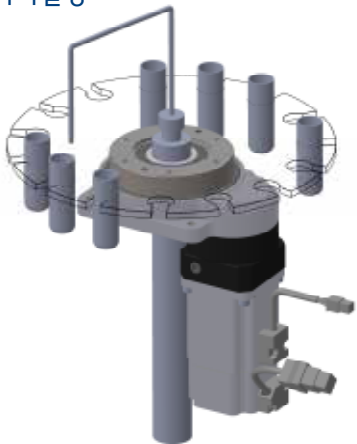

○ 모멘트 하중의 변위 구조



KG T

- Robonic
- CYKO
- KSB
- KSBL
- KSE
- KSEL
- KSBT
- KSD
- KSDL
- KSF
- KSFL
- PGX
- PBL
- PBT
- KFA
- KSN
- KFB
- KFE
- PE
- KG T**
- KST
- KHY
- KHK
- KHF
- KWE

Hollow Rotary Reducer and Motor Mounting Instructions



모터와 기어박스의 사이즈를 확인 후
마운팅 표면을 깨끗이 닦아 주세요.
Confirm the motor, and gearbox size.
Clean up the mounting surface.

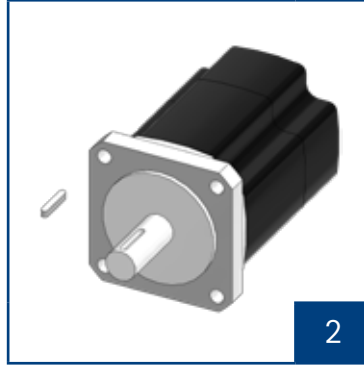

모터 샤프트의 키를 제거합니다.
Remove the motor key..



모터의 사이즈를 확인하시고 필요시에는
부싱을 삽입하세요.
Check motor shaft size and insert
bushing into input bore if necessary.



아답터 플레이트의 스크류 플러그를 제거하신
후 세트컬러의 볼트를 회전시켜 주세요.
Remove the plug on the adapter plate.
Rotate the set collar till the bolt is line
up.



모터와 기어박스를 연결합니다.
Put the motor into the gearbox vertically.



토크 렌치를 사용하여 마운팅 볼트를
조여 주세요.
Tighten the mounting bolt in 1~4
order with torque wrench.

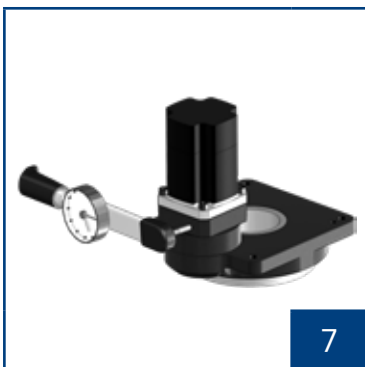

토크 렌치를 사용하여 세트컬러의 볼트를
조여 주세요.
Tighten the set collar bolt with torque
wrench.



스크류 플러그를 조여 주세요.
Tighten back the screw plug.

1. 주의할 점은 반드시 모터를 먼저 취부한
이후에 세트컬러를 조여 주셔야 합니다.
2. 6번 단계와 7번 단계순으로 조립해
주시길 바랍니다.
3. 감속기와 서보모터는 반드시 그림 5와
같은 방향으로 조립해 주시기 바랍니다.
그림 5와 반대로 감속기가 위에 있고
서보모터를 밑에서 조립하거나 또는
수평인 상태에서 조립할 경우에는
세트컬러가 흘러내려 체결될 가능성이
있어 서보모터 플랜지와 간섭이 발생되면
고장의 원인이 될 수 있습니다